

# KRENDL

## Fiber Moving Equipment



### OWNERS MANUAL MODEL #450A



### 50 YEARS OF QUALITY AND SERVICE

---

KRENDL MACHINE COMPANY • 1201 SPENCERVILLE AVE  
DELPHOS, OHIO 45833 • TELEPHONE 419-692-3060 • FAX 419-695-9301  
E - MAIL: [krendl@krendlmachine.com](mailto:krendl@krendlmachine.com) • WEB SITE: [www.krendlmachine.com](http://www.krendlmachine.com)

---

**CONGRATULATIONS ON YOUR PURCHASE OF KRENDL EQUIPMENT**

**MODEL #450A  
OWNER'S MANUAL**

FOR ASSURED SAFETY AND CONFIDENCE, PLEASE READ THIS MANUAL CAREFULLY BEFORE INSTALLING AND OPERATING YOUR MACHINE.

**E-MAIL ADDRESS IS: [krendl@krendlmachine.com](mailto:krendl@krendlmachine.com)  
WEB SITE IS: [www.krendlmachine.com](http://www.krendlmachine.com)**

# Table of Contents

	PAGE
INTRODUCTION.....	1
GENERAL SAFETY INFORMATION.....	2-3
DECALS .....	4-5
RETURNED GOODS PROCEDURE .....	6
WARRANTY .....	7
ASSEMBLY.....	8
BASIC COMPONENTS.....	9
THEORY OF OPERATION.....	9
OPERATING INSTRUCTIONS	
Machine Hook-up.....	10
Electrical Operation.....	11
Mechanical Settings.....	12
GENERAL MAINTENANCE.....	13-16
ELECTRICAL SYSTEM.....	17-19
LADDER DIAGRAM .....	20
TROUBLESHOOTING.....	21-23
PARTS LIST.....	24-29
GLOSSARY.....	30
SERVICE RECORD.....	31

## INTRODUCTION

Thank you for purchasing a **KRENDL FIBER MOVING MACHINE**. With over fifty years experience in manufacturing fiber moving equipment, we have designed and built your machine with the highest quality to provide years of reliable service.

This manual has been prepared to help you obtain the maximum efficiency and service from your Krendl equipment. The machine is designed to condition and apply fibers with the utmost in dependable performance. Our primary objective is to build equipment which will provide complete satisfaction so that you may confidently recommend Krendl to others.

We do **not** manufacture or sell fibers. Our interest lies only in the proper performance of the equipment we manufacture. We make no recommendations or guarantees concerning various fibers.

### CAUTION:

 This manual contains important information regarding the **safe** assembly and operation of your machine. We urge you to read it carefully and follow the instructions provided. If your questions are not answered in this manual, may we hear from you? We want you to be able to operate this unit safely and confidently.

**UNPACKING:** Store and unpack carton with correct side up. Unpack your machine **IMMEDIATELY** and check for damage in shipping. **Place any damage claim with delivering carrier, saving all packing materials for inspection.** Our warranty covers manufacturer's defects only. **DO NOT** return to shipper.

### FILL IN AND RETAIN:

Krendl Machine Company  
1201 Spencerville Ave  
Delphos, Ohio 45833 U.S.A.

Telephone: 419-692-3060  
Fax: 419-695-9301  
E-mail: [krendl@krendlmachine.com](mailto:krendl@krendlmachine.com)  
Web Site: [www.krendlmachine.com](http://www.krendlmachine.com)

For your protection in the event of theft or loss, please fill in the information requested for your own records. This information will be needed for in-warranty repairs. You may also want to attach a copy of your invoice.

Machine model number \_\_\_\_\_ Blower motor manufacturer \_\_\_\_\_

Serial number \_\_\_\_\_ Agitator motor manufacturer \_\_\_\_\_

Blower(s) serial number(s) \_\_\_\_\_ Speed reducer manufacturer \_\_\_\_\_

Date of purchase \_\_\_\_\_ Supplier \_\_\_\_\_

The model and machine serial numbers are located on the base of the machine unit. The blower(s) serial number(s) is located on the motor housing of blower.

## GENERAL SAFETY INFORMATION

 **Important:** Read **all** instructions **before** operating this unit. This equipment can be potentially dangerous and must be used in strict accordance with instructions.

 **Disclaimer Notice:** The manufacturer will not be legally responsible for any injury or damage resulting from the improper use of this equipment or the failure to follow instructions.

### Unpacking

Handle cartons with care to avoid damage from dropping or bumping. Store and unpack cartons with the correct side up. Completely remove machine from the packaging and from any shipping pallet or skid to which it might be attached. In addition, completely remove **all** shipping materials from **inside** the machine.



### General Safety

1. Read this manual carefully and become familiar with your machine unit. Know its applications, limitations, and any hazards involved.
2. This machine was designed and manufactured for specific applications. Do not attempt to modify the unit or use it for any application it was not designed for. If you have any questions about your intended use or the machines suitability, ask your dealer/distributor or consult the factory. The manufacturers' could not possibly anticipate every circumstance that might involve a hazard. For that reason, warnings in the manual and warning tags or decals affixed to the unit, are **not** all-inclusive. If you intend to handle, operate, or service the unit by a procedure or method not specifically recommended by the manufacturer, first make sure that such a procedure or method will not render this equipment unsafe or pose a threat to you and others.



### Electrical Safety

- The **National Electric Code** (NEC) in the United States and many international electrical codes require frame and external electrically conductive parts of this machine to be properly connected to an approved earth ground. Local electrical codes may also require proper grounding of machine. Consult with local electricians for grounding requirements in your area.
- Never handle any kind of electrical cord or device while standing in water, while barefoot or while hands or feet are wet. Dangerous electrical shock will result.
- Use a ground fault circuit interrupter (GFCI) in any damp or highly conductive area. (metal decking or steel work)
- Reference NFPA 79, 70E, or OSHA safe work practices when performing energized work procedures.



### Safety/Caution

- **Be Safe** - Keep away from moving parts.
- **Be Safe** - Make sure all guards and hopper bar are in proper place **before** operating machine. Guards and safety devices/switches should not be removed, modified or by-passed. Hands should **never** pass below hopper bar.
- **Be Safe** - Do not remove motors or lift hopper when unit is connected to power supply.
- **Be Safe** - Make sure machine is properly grounded. Protect all electrical supply cords from sharp objects, moisture, and other potentially hazardous materials. Keep power cords in good repair. Electrical service must be performed by a qualified electrician.
- **Be Safe** - Disconnect power supply **before** inspecting or adjusting unit.
- **Be Safe** - Consult a qualified technician to answer questions **before** attempting to operate, or injury may result.
- **Be Safe** - Do not operate machine alone.
- **Be Safe** - Do not leave machine unattended and energized.
- **Be Safe** - Turn machine off and disconnect electricity before clearing and feeding jam or attempting to remove any object dropped in the hopper.
- **Be Safe** - Keep hands, loose clothing, jewelry and hair away from agitators, gears, chains and other moving parts.
- **Be Safe** - Use proper lifting when moving fibers and loading machine.
- **Be Safe** - Keep work area clear of debris.
- **Be Safe** - Wear proper safety equipment, including protective gear, such as respirators, eye and ear protection.
- **Be Safe** - Violation of the Owner's Manual or safety precautions may void warranty.



### Make Sure!

- Hopper is empty of foreign objects **before** starting.
- Adequate electrical power is supplied or damage to unit will result.
- Blower filter is kept clean and in place when blower is on.
- Machine is turned off **immediately** if hose is plugged, or blower will overheat.
- Machine must be on **before** adding fiber.
- Blower(s) must be on, when agitators are running, or machine will bind.
- Agitator motor is not run with hopper empty for more than a few minutes, or damage to seals will result.
- Sprockets, chains, belts and pulleys are correctly **aligned** and **tensioned**.
- Pieces of bag are **not** left in the machine as this can bind and stall your machine.
- This machine should only be used with good quality fibers that are dry, undamaged and that meet a certain industry specification or quality standards.

**DECALS**



Keeping the filter clean will result in longer blower life and better performances.



Rotating parts will be moving in this direction.



Manufacturer information is provided here.

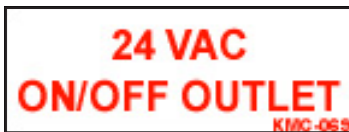

Specifies the voltage this outlet is rated for.



Part number for identification and tracking.

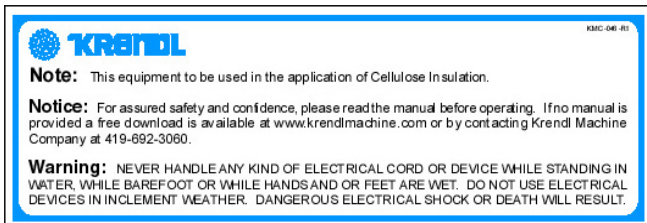

Identifies what type of insulation should be used with this machine and that the manual should be read before operating. Warns to be careful around electrical components! This can cause serious injury or death.



Rotating parts can be dangerous! You can snag clothes, skin, hair, hands, etc. This can cause serious injury or death.



Emergency stop button for machine.

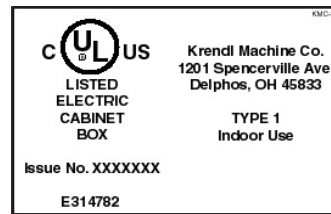

Indicates that the electrical box on the machine is in compliance with UL codes.



Identifies position of material feed gate.



General safety information intended to reduce the risk of serious injury or death



Reset button for motor.



Made in the U.S.A.



Indicates which employee inspected equipment and on what date.



Indicates that this outlet is intended for only the remote control outlet. Each time machine cycle starts, an audible alarm warns the operator that the machine is about to come on.



Manufacturer information is provided here along with machine model, and serial number.



Operating machine at specified voltage will result in longer machine life and better performance.



Indicates that this outlet is intended for only the wireless remote. Each time machine cycle starts, an audible alarm warns the operator that the machine is about to come on.

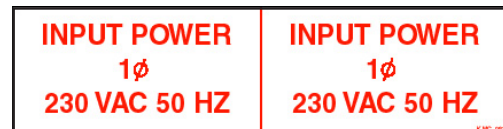

Indicates the input power of the machine.



Identifies if machine is in remote mode, manual mode, or off position. In manual mode this switch operates machine. In remote mode the hand pendant operates machine. Each time machine cycle starts, an audible alarm warns the operator that the machine is about to come on.



Indicates if blower is off, on, or on with agitator.

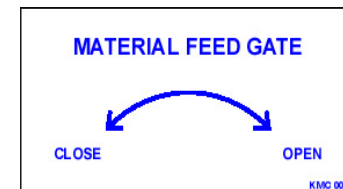

Opens and closes the material feed gate which in turn controls the production.

**RETURNED GOODS PROCEDURE:**

IF MACHINE WAS NOT PURCHASED DIRECTLY FROM KRENDL MACHINE COMPANY, CONTACT YOUR SUPPLIER / DISTRIBUTOR.

When returning products to Krendl for repair, first obtain a return goods authorization, at which time you will be given shipping instructions. The product must be shipped **PREPAID**:

**Krendl Machine Company**

1201 Spencerville Ave.  
Delphos, Ohio 45833 U.S.A.

Telephone: 419-692-3060

Fax: 419-695-9301

E-mail: [krendl@krendlmachine.com](mailto:krendl@krendlmachine.com)

Web Site: [www.krendlmachine.com](http://www.krendlmachine.com)

Once the unit is received, it will be inspected. In-warranty units will be repaired and returned immediately. An estimate of repair charges will be provided for out-of-warranty units.

**WARRANTY:**

Krendl Machine Company (Company) warrants to each original purchaser (Buyer) of its machines that such products will be free of manufacturing defects for a period of 2 years from the date of shipment to the Buyer. (This does not include accessories, pumps, blowers, wall scrubbers, etc.)

No warranty is made with respect to:

1. Components or accessories manufactured and warranted by others. Warranties for purchased component parts as supplied from vendor such as engine, electric motor, blower, gearbox, transmission, etc., if furnished by the manufacturer of the component, are on file at the Company's main office and copies will be furnished at request of Buyer. Component(s), shipping costs prepaid, shall be sent to Company who in turn shall forward to vendor for evaluation and warranty determination.
2. Any defect caused by repair, alteration and/or adjustment performed by Buyer or customer/ vendor of Buyer without the express written authorization of the Company.
3. The labor costs of replacing parts by parties other than the Company.
4. Any machine that has not been operated and/or maintained in accordance with normal industry practice and the written recommendations of the Company. (e.g. machine operated with an improperly sized, worn or damaged hose, improper or inattention to preventative maintenance, etc.)
5. The product has been subjected to misuse, negligence or accident or results of any application or use of the blowing equipment not in accordance with the Company recommendations.

This limited warranty does not cover the free replacement of component parts that become inoperative due to wear and usage and need to be replaced on a regular basis, including but not limited to: airlock seal(s), agitator(s), shredder(s), auger(s), fuse(s), switch(es), clutch(es), hose(s), shaft seal(s), chain(s), belt(s), sprocket(s), pulley(s), bearing(s), cable(s), battery(ies), filter(s), fan(s), etc.

The Company's obligation under this warranty is limited to repairing or replacing (at Company option) any part that is determined by the Company to be suffering from a manufacturing defect. The Company (at Company option) will provide any required parts and labor to the Buyer. If the equipment or parts must be returned to the Company for repair, all transportation costs shall be the Buyer's responsibility.

**THIS LIMITED WARRANTY IS EXPRESSLY IN LIEU OF ANY OTHER GUARANTEES AND / OR WARRANTIES, ORAL OR WRITTEN, EXPRESSED OR IMPLIED, INCLUDING WITHOUT LIMITATION, THE IMPLIED WARRANTY OF MERCHANTABILITY. NO WARRANTY, EXPRESS OR IMPLIED, OTHER THAN THE AFORESAID WARRANTY IS MADE OR AUTHORIZED BY COMPANY. COMPANY SHALL NOT BE LIABLE FOR ANY DIRECT, INDIRECT, INCIDENTAL OR CONSEQUENTIAL DAMAGES TO PROPERTY OR INJURY TO ANY PERSON OR COSTS ASSOCIATED WITH LOSS OF PRODUCTION RESULTING IN LOSS OF REVENUE, PROFITS OR LOSS OF EQUIPMENT THROUGH THE USE OF THIS EQUIPMENT.**

**Note: Special job circumstances incurring costs for specialized repair and next day delivery of parts will not be reimbursed by the manufacturer unless authorized by factory.**

**ASSEMBLY**

Prior to packing, your machine has been assembled and tested to assure quality performance. However, to safeguard against damage in shipping, certain items are packaged separately within your carton and will need assembly.

**POWER CORDS:**

Female receptacle(s) need to be wired properly to main power cord(s). (Consult electrician for assistance.) Units shipped to European countries will have standard (2) two prong 230V 16 amp plugs supplied. Units shipped overseas to other than Europe do not have plugs and receptacles on input cords due to the varying electrical plug configurations in different countries, unless provided by Krendl agents or suppliers.

**ASSEMBLY OF OPTIONS:**

Standard Wheel Package: 9" Pneumatic Wheels or 10" Hard Wheels (See illustration A)

Bushing Reducer: (2")

Bushing reducer inserts into output tube of airlock. Press reducer firmly against shoulder and tighten two hold-down bolts to secure unit in place. The bushing reduces the size of opening to hose at its source, providing a more consistent feed while preventing hose plugs. (Standard output tube diameter on model #450A is 2 1/2".)

Loading Tray: (Packaged separately) (See illustration B)

Attach Loading Tray to machine with bolts provided.

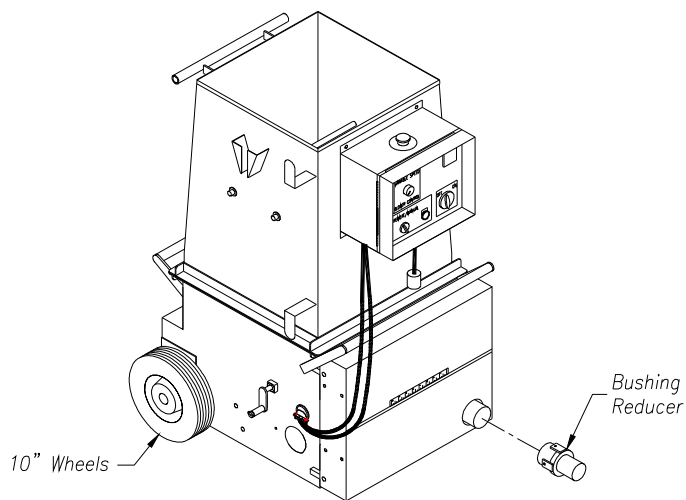

(illustration A)

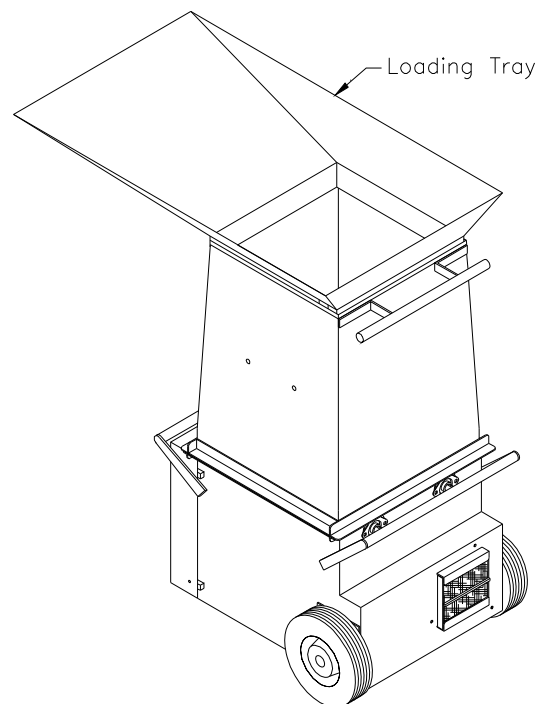

(illustration B)

## BASIC COMPONENTS

This is a view of the basic components of your machine. It shows the location of each item and gives the function of each. Use this as a guide throughout the manual.

(illustration C)

- A) BASE UNIT** — Lower frame unit supporting blower, speed reducer, motor, airlock and hopper.
- B) AIRLOCK** — Traps air and fiber while providing a metered flow.
- C) SLIDEGATE** — Meters the amount of fiber dropping into the airlock by controlling size of airlock opening.
- D) MOTOR / REDUCER DRIVE**—Provides driving power for agitator/airlock system.
- E) AGITATOR** — Conditions fiber in the hopper.
- F) HOPPER** — Upper unit of machine holding fiber.
- G) MAIN CONTROL PANEL** — Connects with main power, allowing operation of unit at machine or Remote Cord.
- H) KILL SWITCH** — Safety device for immediate stopping of machine
- I) REMOTE CORD HANGER** — Storage for remote control cord. (Not Shown)
- J) LOADING TRAY (optional)** — Increases overall hopper capacity and ease of loading.

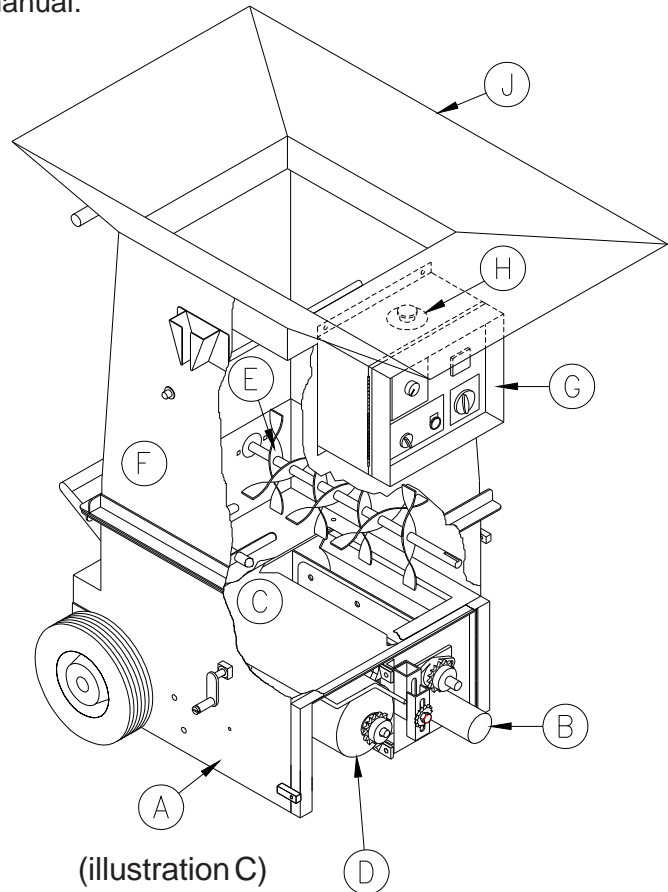

## THEORY OF OPERATION

This unit is designed to accept all fiber materials into the hopper area of the machine, passing through a multistep agitation system and dropping into the rotating airlock feeder. (see illust. D) The airlock feeder has a crankgate control providing precision feeding of fiber for open blowing, sidewall blowing, and spray-on applications. Fiber is then rotated to a 6:00 o'clock position where air from the blower motor pushes fiber from the rotating chambers through the hose. Material and air is prevented from escaping into the machine while in the airlock by six rubber seals which conform to the airlock inner wall as the chambers revolve. The blower motor is either a two or three stage, high speed unit with low amperage designed to blow air. (Fiber does not pass through the blower fan chamber.) The high pressure and adjustable volume provides low amperage, low noise, and minimal attic dust. This reduces hose plugging problems and gives longer blower life.

Note: All Fiber/airlock machines provide slightly less coverage than thru-blower machines. Airlock machines cannot duplicate the high speed (13,000 r.p.m.) conditioning effect of fiber passing through the blower. These units blow the fiber closer to settled density.

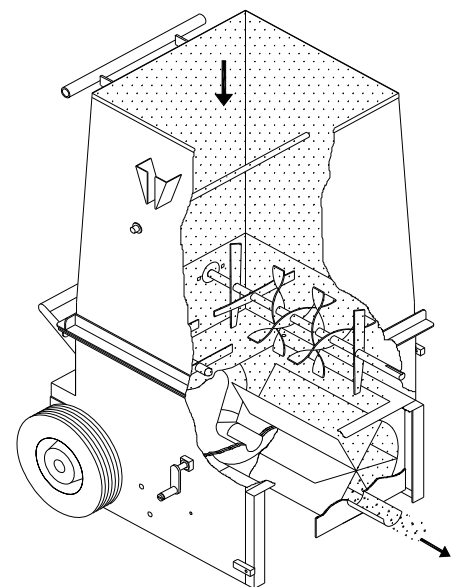

**OPERATING INSTRUCTIONS: MODEL #450A****Machine Hook-up**

This unit comes ready for connection to insulation hose, power cords, and accessories.

This unit provides a direct connection to 2 1/2" insulation hose. Slide hose on to outlet and secure with a hose clamp. All hose connections must have hose clamps to prevent air leakage from blower to nozzle. This helps to prevent hose plugging.



Remove remote control cord, packet, accessories, ect. from hopper and plug remote control cord into **Main Control Panel** located in the hopper area. (See illustration E)

The first bag of insulation into hopper should be well broken by hand to assist agitator action. **Caution:** Hopper bars **must** be in place while loading hopper. **Never** put hands below bars or force feed fiber by pushing down on insulation.

When assembling unit, make sure remote control **hand pendant** switch is in the **off** (middle) position and close **slidegate**.

1. Connect power to Input Cord(s) located below Main Control Panel. (See illustration E)



On double input units, **both** input cords must be supplied with power from two separate sources for unit to work properly. When using extension power cords, wire gauge size should not be less than input cord on unit and not to exceed 50' in length. **Caution:** Operating unit with less than required voltage or inadequate generator size will result in damage to electrical components. This machine is marked with the correct input voltage on input cords located on bottom of the Main Control Panel. **Do not** operate machine with less than required voltage. Damage to motors and other electrical parts will result. Check voltmeter on Main Control Panel when machine is running.

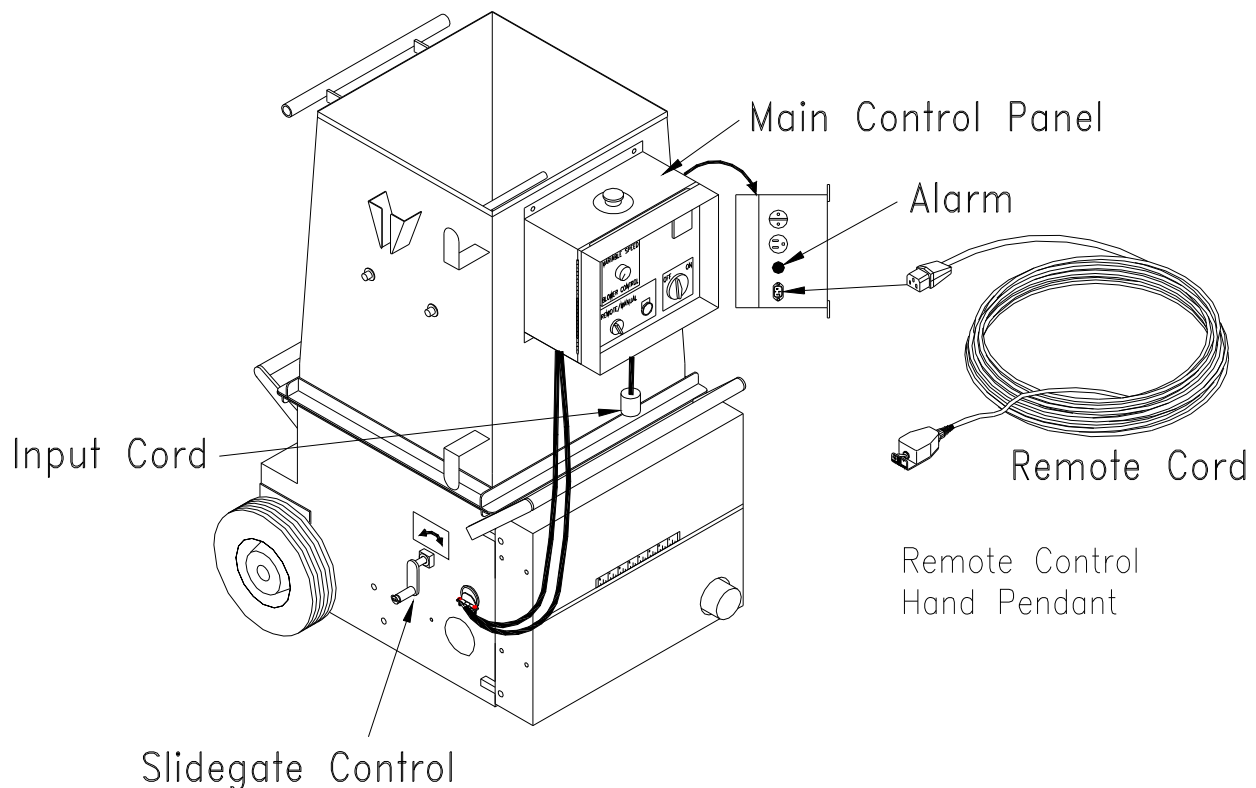

(illustration E)

## Electrical Operation

**PRESS KILL SWITCH TO IMMEDIATELY STOP MACHINE AT ANY TIME!**

1. Make sure Kill Switch is out by pulling. (See illustration F)
2. Turn Main Disconnect Switch to ON position. (See illustration F)
3. Set 4-Position Selector Switch to OFF. (See illustration F)
4. Press *green* start Button. **Machine will not run unless start button is pressed after Kill Switch is out and Main Disconnect Switch is on.** (See illustration F)
5. Select operating mode on 4-Position Selector Switch from one of the following options:

- Remote:** Remote control hand pendant will control machine.  
**Off:** Machine will not run. (overrides remote hand pendant)  
**Blower:** Only the blower will run continuously. (manual control at machine)  
**Agitator-Feed/Blower:** Both the blower and the agitator-feed will run continuously. (manual control at machine)

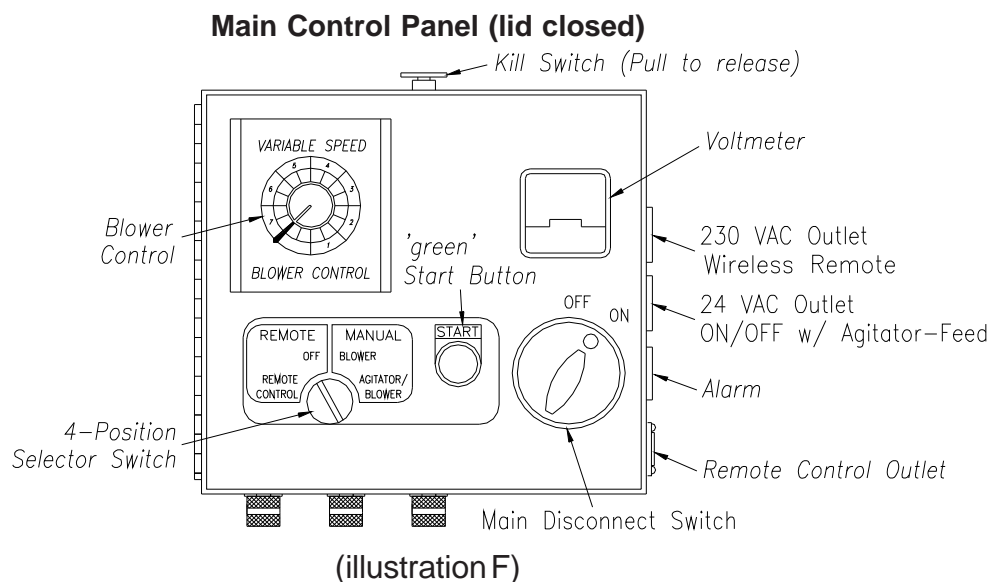

6. When operating in **Remote mode**, the 4-Position Selector Switch must be set to **Remote** position. (See illustration F)
7. Remote control hand pendant positions will be selected from the following:

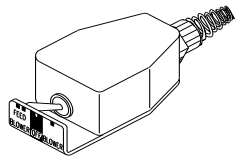

- BLOWER-FEED** - operates both **blower motor** and **agitator-feed motor** simultaneously  
**OFF** - (middle position) all functions stop  
**BLOWER** - operates the **blower motor** only

8. Adjust blower and slidegate to desired settings. (See page 12)
9. **To adjust alarm time**, follow the procedure below: (See illustration G)

- a) Unplug machine from power source.
- b) Turn **off** Main Disconnect Switch, loosen two screws in door, and open Main Control Panel lid.
- c) Turn Timer Relay knob to desired setting. (clockwise to **increase** warning time)
- d) Close lid, tighten two screws in door, plug in machine, turn on Main Disconnect Switch and press *green* Start Button.
- e) Retest machine.

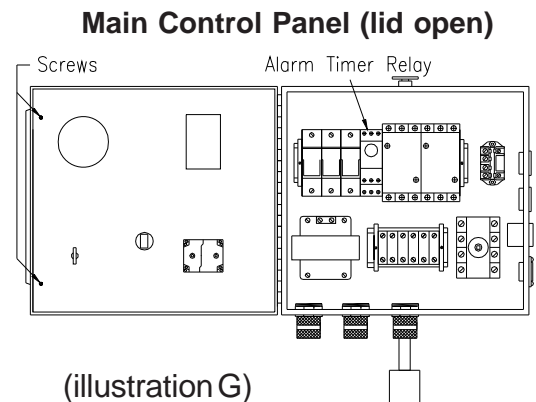

## Mechanical Settings

The control end of your machine contains the blower and slidegate controls to adjust your machine for each application and type of fiber. (See illustration H) **Blower control** (air) and **slidegate** (material feed) are adjusted according to:

- APPLICATION: Open blow, retro-sidewall and spray-on applications require varying amounts of control.
- TYPE OF MATERIAL: Cellulose, fiberglass, and mineral wool have different textures and densities that respond to machine settings.
- HOSE: Corrugations or roughness of interior surface, diameter, length and elevation of hose will also require varying adjustments.
- WEATHER CONDITIONS: Temperature and humidity may require day to day adjustment of machine settings.

### BLOWER CONTROL AND SLIDEGATE GENERAL SETTINGS:

Blower control can increase or decrease the amount of air in the system, affecting the velocity (speed) and spread rate (coverage) of fiber. (See illustration H) The blower control dial operates clockwise, from HIGH to LOW, controlling air pressure and amount of air.

Opening or closing slidegate (material feed) controls the amount of fiber dropping into the airlock which changes the production rate (lbs. per hour). (See illustration H) For calibration purposes the scale located on output tube side of machine indicates how many inches the airlock slidegate is opened.

The blower and slidegate controls **working together** affect the distance fiber can be blown through a hose without plugging. These controls also affect the accurate blowing of fibers for spraying applications.

These settings control the following:

- **Density** of fiber blown in retro-sidewall application.
- **Velocity** of material impact when spraying.
- **Dust** on open blow.
- Material **spread rate** or coverage.
- **Production** rate (lbs. per hour blown).

### GENERAL BLOWER/SLIDEGATE SETTINGS:

Since specific settings need to be determined by each operator, the following are only suggested guidelines. Consult the fiber manufacturer for additional recommendations specific to **their** product.

APPLICATION	BLOWER CONTROL	SLIDEGATE
Open Blow	High	Full Open
Sidewall-Retrofit	High	Half Open
Wall Cavity Spray	Medium	Half Open
Commercial Spray (Adhesive)	High	One-third Open

### GENERAL BLOWER CONTROL AND SLIDEGATE SETTINGS FOR OPEN BLOW:

(See illustration H)

With the **slidegate** closed, turn **agitator-feed motor on** and variable speed blower control on low. Fill hopper with insulation and adjust **blower control** and **slidegate**. In making adjustments, move controls proportional to each other. (i.e. If variable speed **blower control** is half speed, **slidegate** should be half open.) Open slidegate to allow fiber to drop into the airlock providing good production, but not beyond point where hose plugs. As hose length is increased, the **blower control** speed is increased while closing the **slidegate** proportionally. This will increase the distance fiber can be blown through the hose and improve material coverage rate, while decreasing the blowing production rate (lbs. per hour blown). These adjustments are for open blow. If specialty application or retro sidewall work is done, refer to General Blower/Slidegate Settings chart (below left) or fiber manufacturer.

### Control End of Machine

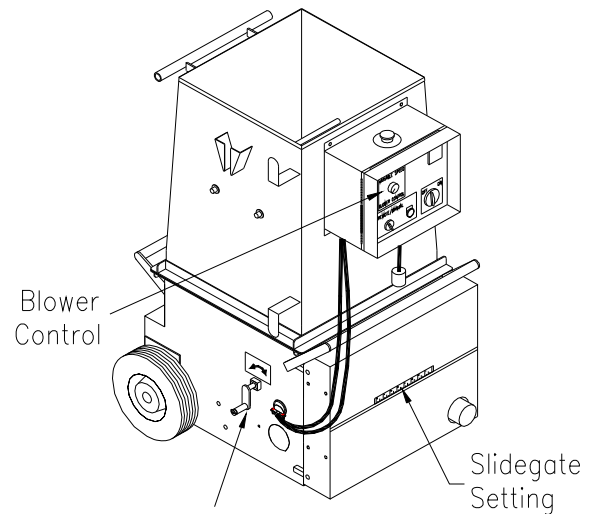

(illustration H)

## GENERAL MAINTENANCE

Periodic preventive maintenance will add years of life to your equipment. Reviewing the information in this manual will go a long way in reducing downtime and lost income. **Remove hopper** for easy maintenance of lower base unit.



**KEEP CLEAN:** During operation, keep material from accumulating on Blower Filter. Always keep Filter in place while operating machine. After each use, remove fiber from hopper and blow out hose. (Use **BLOWER** mode at Main Control Panel or Hand Pendant.) **Clean air** from insulation hose can then be used to blow fiber from agitator motor and Blower Filter area.

### AIRLOCK:

**SEAL REPLACEMENT:** The purpose of the airlock seal is to trap air and fiber until it rotates 180° to the 6:00 o'clock position. At this point, fiber is pushed by air from the blower, out of the chamber. Worn or damaged seals allow air and fiber to escape back into hopper, thus reducing production and coverage. When it is necessary to replace seals, follow these directions:

Airlock rotor plates that are damaged (bent) will need replaced. (Refer to Rotor Replacement below.) Take out rubber seal by removing three plate fastening bolts and nuts and top plate. To install a new seal, reverse procedure. Seal should be inserted tight against the rotor plate, pressing the lower tabs of seal down under the adjacent seal with a flat blade screwdriver. (See illustration I) Make sure all bolt holes are aligned while each side of seal is equally pressed against the end plates. Seal should be bent backwards for **counterclockwise** rotation.

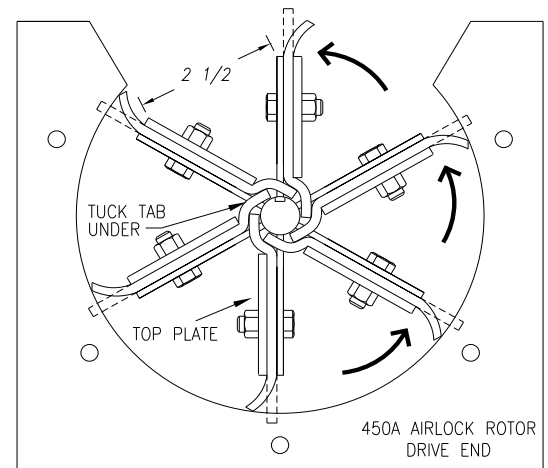

(illustration I)

### ROTOR REPLACEMENT:

1. To check plates for proper angle, measure distance between outer edge of metal plates. (See illustration I) This measurement should be 2 1/2". Measure all six plates and replace rotor if needed.
2. Remove top plate and seal from rotor. Check seal and top plate for wear and/or damage.
3. Loosen set screws on locking collar of bearings on each side of airlock.
4. Remove sprocket, bolts and endplate from the **sprocket end** of airlock. (See illustration J)
5. Remove old rotor and replace with new rotor.
6. Caulk the endplate ring of airlock chamber with silicone. (See illustration J)
7. Slide endplate onto rotor shaft and reattach with bolts. Reinstall sprocket and tighten set screws on locking collar of bearings.
8. Install seal and top plate. As seal and top plate are installed, press bottom tab of seal under adjacent seal with flat blade screwdriver. (See illustration I) Make sure seal and top plate are assembled on **correct** side of rotor plate before assembling in airlock. Seal should press backward towards top plate when installed correctly into airlock chamber. The airlock runs **counterclockwise** viewing it from the sprocket drive shaft. (See illustration J) **Caution:** If installed improperly, damage to seals will result and put undue stress on agitator motor. This causes overheating and poor production. Seal should be bent backward to allow for a **counterclockwise** rotation of rotor.

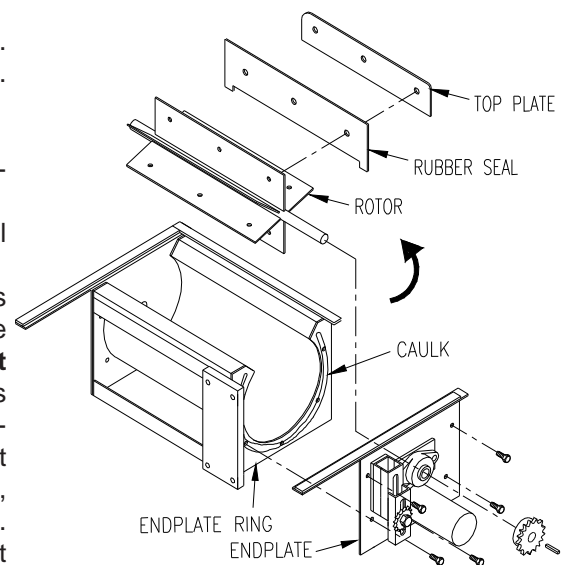

(illustration J)

## General Maintenance (cont.)

### CHAIN: (#40 Nickel Plated)

**ADJUSTMENT:** A smooth operating chain drive should have a slight sag on the idler side of the chain. New chains should be installed under slight tension as they will elongate a small amount due to seating of pins and bushings during the first few days of operation. Chain should be kept in good condition by proper lubrication (dry film lubricant Dow 321) and occasional cleaning. Soaking chain in container of 10 weight oil will provide for internal lubrication of pins and bushings. However, excess oil must be drained and wiped away as excessive lubrication will cause fiber accumulation on chain. Worn out chain should be replaced. When chain is replaced, worn sprockets should also be replaced, preventing further damage to new chain.

### SPROCKETS:

**CHECK SPROCKETS FOR WEAR.** Misalignment and/or loose sprockets and improper chain tension causes the premature wear of chain and sprockets. All sprockets, except speed reducer and idler sprockets, have been secured with a medium grade Loctite (general purpose thread locker), to prevent gradual movement. The set screws and key are also inserted with a medium grade Loctite. If sprocket is difficult to remove, it may be heated with a propane torch to loosen.

 **Caution:** Do not overheat sprocket or damage to bearing will result. A pulley or bearing puller can then be used to remove the sprocket and key. Replace new sprocket on shaft with key and medium grade Loctite applied to shaft. Align sprocket with corresponding sprocket, using a straightedge placed along face of teeth and tighten set screw. Motor / Reducer drive sprocket does **not** require Loctite.

### BEARINGS:

**AGITATOR BEARINGS** in base unit are prelubricated, double-sealed, self aligning ball bearings. **No** lubrication is necessary. If bearings produce noise or heat (*too-hot-to-touch*), the bearings should be replaced.

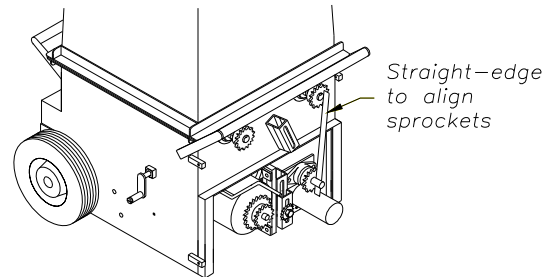

**AGITATOR BEARING REPLACEMENT:** Spray area with rust penetrant (WD-40). Remove sprocket (See SPROCKET section above). Remove the two bolts from bearing flange and outer flange from bearing insert. Loosen set screws on bearing hub at each end of agitator shaft. Since all set screws are installed with a medium grade Loctite, a propane hand torch may be used to assist in removing them. Do not overheat unit, causing shaft to expand. Using a rubber mallet, drive agitator shaft an inch in one direction, creating a space between hopper and bearing unit. A bearing puller can then be used to remove the bearing. Eliminate any metal burrs from shaft with file and install new bearings with felt seals. Use a medium grade Loctite on set screws before securing bearing to shaft.

**AIRLOCK BEARINGS** are prelubricated, double sealed, self aligning ball bearings. Lubrication **is** required at three month intervals of normal running time, or sooner if bearings produce a noise or become *too-hot-to-touch*. Relubrication at the grease fittings is done with a lithium base grease conforming to a NLGI GRADE TWO consistency. The grease should be pumped in slowly until a slight bead forms around the seals. This bead, in addition to acting as an indicator of adequate lubrication, provides additional protection against the entry of foreign matter. **Important:** If a slight bead does **not** form indicating a failure of lubrication or if bearing shows signs of wear, replace bearing.

**AIRLOCK BEARING REPLACEMENT:** Remove two bolts from bearing and follow steps above for agitator bearing replacement.

### MOTOR/REDUCER DRIVE:

If drive motor runs hot, or unit does not run properly, refer to troubleshooting sections of manual. The drive motor should start quickly and run smoothly. If not, shut motor off **immediately** and check for low voltage, incorrect power supply, or misconnected wiring which could cause motor failure. **These conditions void the motor warranty.** Overload conditions such as bearing failure, sprocket and chain misalignment, or gear failure in the reducer can be detected by checking the electrical current (amperage) compared with nameplate current (amperage) located on the body of the motor.

## General Maintenance (cont.)

**MOTOR/REDUCER REPLACEMENT:** (See illustration K) Unplug blower and motor/reducer drive cords. Remove Chain Guard and drive chain. Remove hopper. Remove both Baffle Cover Plates from inside base unit. Flip base unit upside down and remove Bottom Plate Guard. Open Slidegate completely. Take note of electrical connections and unhook motor/reducer drive wires. Loosen hose clamp on rear airlock input tube. Slide hose off airlock. Remove four bolts from top of airlock and slide motor/reducer drive assembly out of base. Loosen set screw and take sprocket off motor/reducer. Unbolt motor/reducer drive from airlock. Install new motor/reducer drive on airlock. Reverse procedure for assembly.

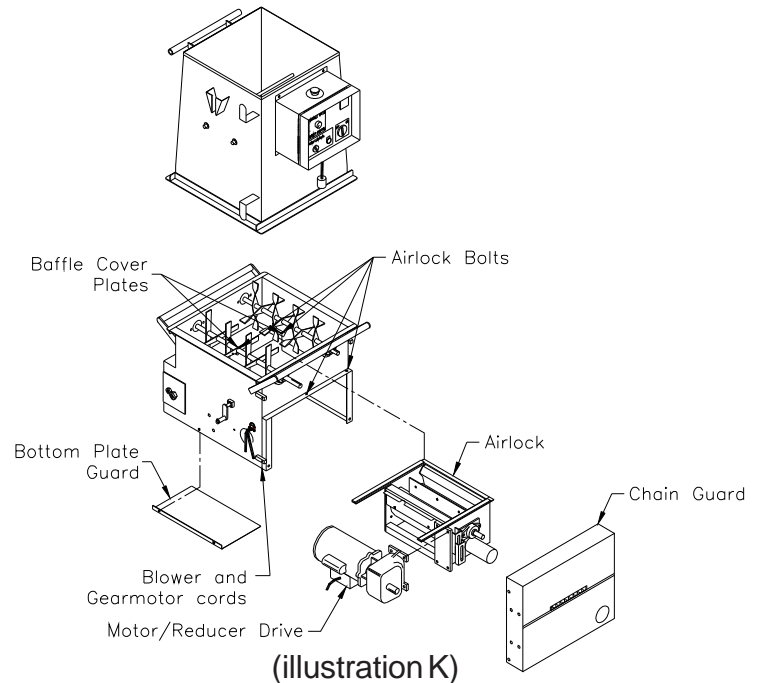

### BLOWER MOTOR:

Periodically turn machine on its side and vacuum any material that has accumulated around blower motor. Blow out any remaining debris around motor and intake orifice of fan with compressed air. This will extend the life of the blower significantly. Blower Filter life can be extended by occasional removing and blowing through with compressed air. Filter should be replaced periodically depending on use. If blower produces noise or heat, refer to troubleshooting section of manual.

**CARBON BRUSH REPLACEMENT 8 AMP (4 AMP 230 volt) 2-STAGE BLOWER:** (See illustration L) Order replacement brushes from your supplier to assure proper brush style. Carbon brushes need to be replaced when excessive arcing is produced on the commutator. This would be evident by an intermittent scratchy sound with loss of blower r.p.m. Replace brushes before brush shunt touches the commutator. Blower needs to be removed for brush replacement. See page 16 for instructions to remove blower.

1. To replace brush assembly; use a flat blade screwdriver to carefully release housing latch located at base of brush assembly. (See illustration L-1)
2. Remove brush holder clamp using a Phillips head screwdriver. (See illustration L-2)
3. **Lightly** tap brush holder at the front/center portion of the unit to release barb on spade of wire connector. (See illustration L-3)
4. Pry spade connector from brush assembly housing and replace brush. (See illustration L-4) If spade connector does not remove easily, repeat step 3. On reassembly and handling, the lead wires must be kept away from rotating parts and motor frame.
5. To achieve best performance, the new brushes should be seated on the commutator before full voltage is applied. To seat brushes, run variable speed blower control on medium speed for thirty minutes after brush change. The motor will return to full performance after an additional thirty to forty-five minutes running period at full voltage (BLOWER CONTROL on high). Application of full voltage directly after changing brushes will cause arcing, commutator pitting, and reduced overall life. Brushes can normally be changed two times before armature and other component replacement is required.

### 8 Amp (4 Amp 230 volt) 2-Stage Blower Motor (Brush Replacement)

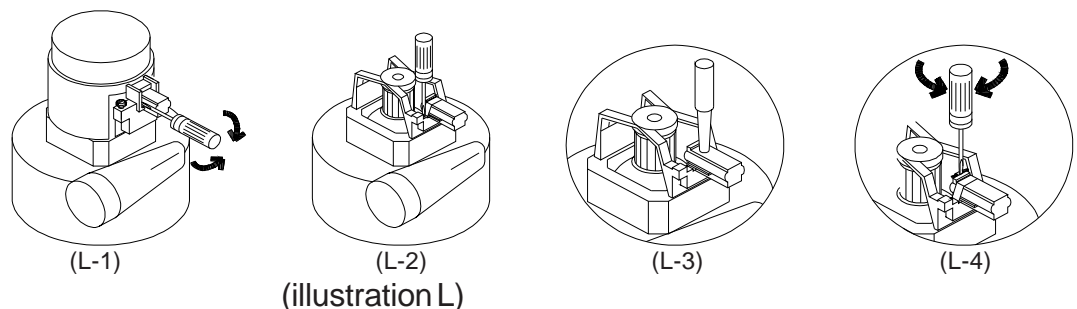

**General Maintenance (cont.)**

**CARBON BRUSH REPLACEMENT for 12.5 AMP (6 AMP 230 volt) 3-STAGE BLOWER:** (See illustration M) Order replacement brushes from your supplier to assure proper brush style. Carbon brushes need to be replaced when excessive arcing is produced on the commutator. This would be evident by an intermittent scratchy sound with loss of blower r.p.m. Replace brushes before brush shunt touches the commutator. Blower needs to be removed for brush replacement. See Blower Replacement instructions below to remove blower.

1. Remove screw and shield from blower. (See illustration M)
2. Unhook wire connected to Brush Assembly.
3. Remove Brush Cover screws by inserting screwdriver through hole in blower housing and turning screw.
4. Pull out old Brush Assembly and install new Brush Assembly and Brush Cover.
5. Connect wire to Brush Assembly and reassemble blower shield. On reassembly and handling, the lead wires must be kept away from rotating parts and motor frame.
6. To achieve best performance, the new brushes should be seated on the commutator before full voltage is applied. To seat brushes, run variable speed blower control on medium speed for thirty minutes after brush change. The motor will return to full performance after an additional thirty to forty-five minutes running period at full voltage (BLOWER CONTROL on high). Application of full voltage directly after changing brushes will cause arcing, commutator pitting, and reduced overall life. Brushes can normally be changed two times before armature and other component replacement is required.

**12.5 AMP (6 Amp 230 volt)  
3-Stage Blower Motor  
(Brush Replacement)**

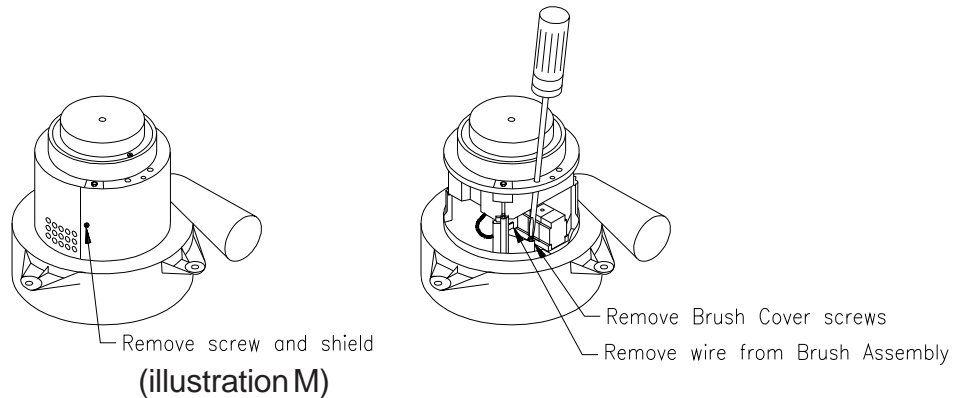

**BLOWER REPLACEMENT:** (See illustration N) Unplug blower and motor/reducer drive cords. Flip base unit on its side and remove Bottom Plate Guard. Loosen hose clamp on rear airlock input tube. Slide hose off airlock. Take note of electrical connections on blower and remove wire nuts from lead wires. Loosen hose clamp and slide hose off blower. Remove three bolts and spacers from machine and remove blower. Reverse procedure for assembly.

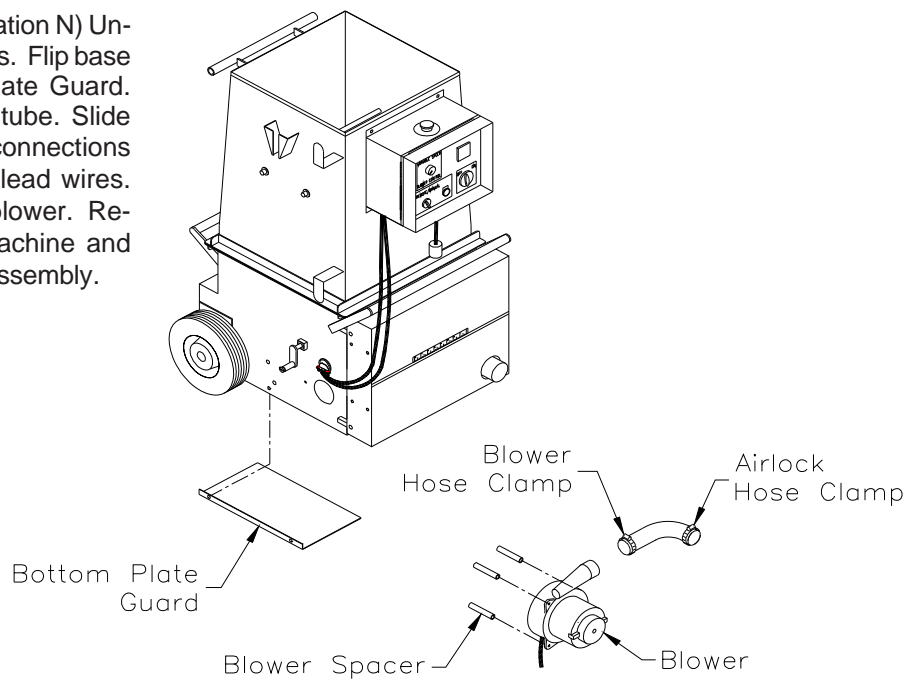

(illustration N)

## ELECTRICAL SYSTEM

**General Operation:** (See illustration O for sequence and illustration F and P for location of components)

This unit is powered by **one** input source connected at the bottom of the Main Panel. Turning the Main Disconnect Switch (switch located on front of Main Control Panel) to the ON position distributes power to the Terminal Boards of the Main Control Panel, Voltmeter, Kill Switch, and the Terminals of the agitator (C2) and the blower (C3) relays. (See illustration F)

When the Kill Switch (mushroom button) is released (closed) and the *green* Start Button is pressed, power is supplied to the dropout relay(s) and the transformer. The transformer supplies 24 VAC to the 4-Position Selector Switch located on the front of the Main Panel Box.

When the 4-Position Selector Switch is turned to MANUAL mode or the 4-Position Selector Switch is set to REMOTE mode with remote control hand pendant switch closed, 24 VAC is supplied to the Pre-Alarm relay, sounding the alarm for a preset time. After the alarm stops, 24 VAC powers the blower (C3) and/or agitator (C2) relays.

If power is interrupted to this system by unplugging either main input cord(s), turning Main Disconnect Switch OFF, or pressing Kill Switch; the *green* Start Button needs to be **pressed** to reactivate the system **after** power distribution into the system has been reestablished. (See illustration P for more details.)

### Electrical Flowchart

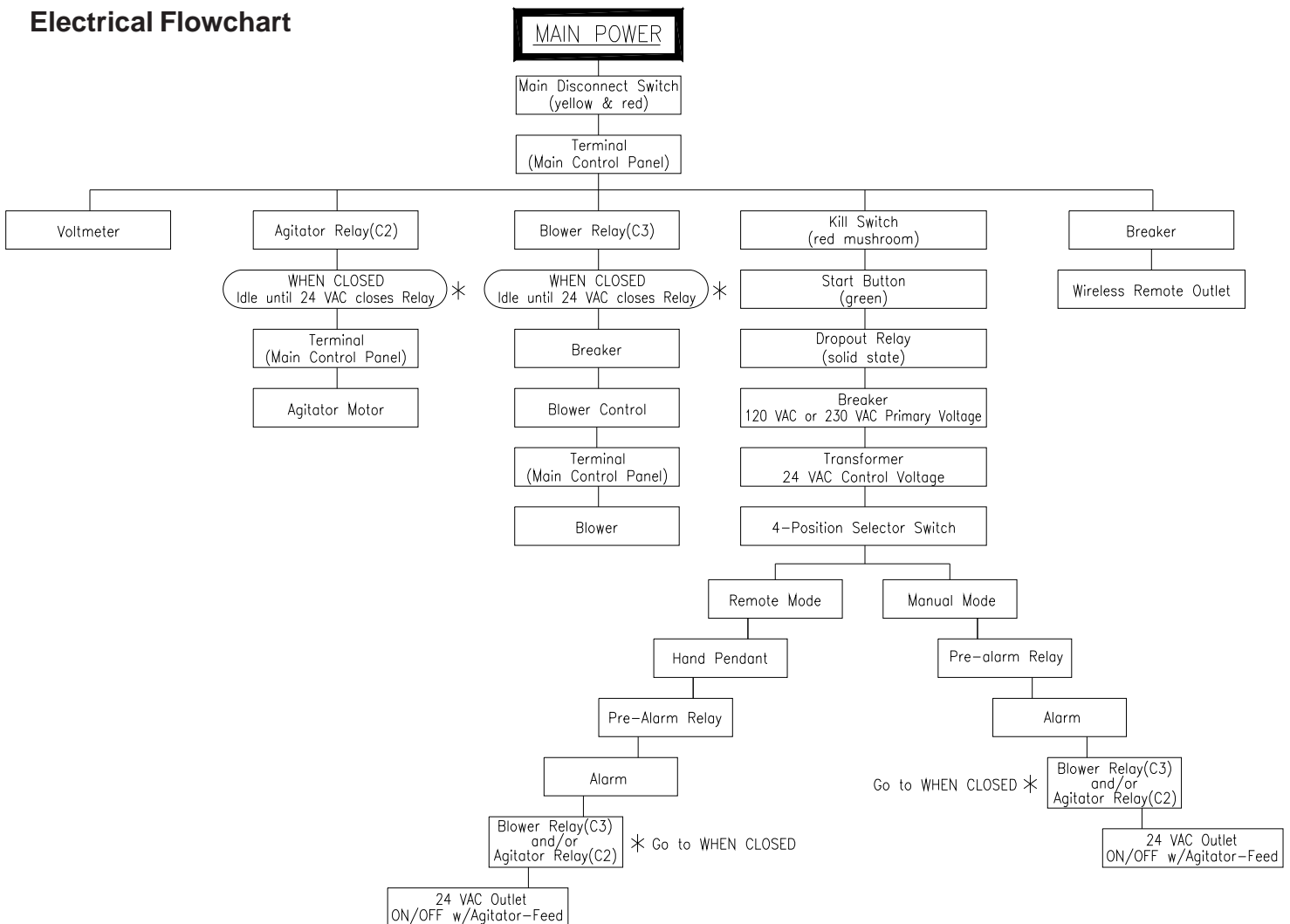

(illustration O)

## Electrical System (cont.)

### Electrical Diagram Description for Page 19:

Tags have been placed at the end of each wire in the electrical system to identify specific wires. This identification code is as follows:

- First letter - identifies component classification
- Second number - indicates specific component
- Decimal number/letter - identifies the terminal on the component

Letter next to identification code indicates **color code**.

Second series of numbers and letters **after dash** which identify connection at opposite end of wire are as follows:

- First letter - identifies component classification
- Second number - indicates specific component
- Decimal number/letter - identifies the terminal on the component

Example: C1.8-4SBL.1

Wire is connected between Relay 1, terminal 8 and Four Position Selector Switch Bottom Left, terminal 1.

### LEGENDS FOR ELECTRICAL DIAGRAM

#### Electrical Component Abbreviations

- TF = Transformer
- C = Relay (C1,C2,C3,etc.)
- D = Disconnect Switch (.L = Disconnect input Line/ .T = Disconnect output Terminal)
- BK = Breaker (BK1,BK2,etc.)
- T = Terminal Board for Main Control Panel
- I = Input Cord
- RI = Right Input Cord (for Blower)
- LI = Left Input Cord (for Agitator)
- O = Outlet (O1,O2,O3,O4,etc.)
- V = Voltmeter
- H = Hand Pendant
- A = Alarm
- K = Kill Switch
- B = Blower (B1, B2, etc.)
- 4S = Four Position Selector Switch
- SB = Start Button
- 4SBL = Four Position Selector Switch Bottom Left
- 4STL = Four Position Selector Switch Top Left
- 4STR = Four Position Selector Switch Top Right
- 4SBR = Four Position Selector Switch Bottom Right

## ELECTRICAL DIAGRAM:

Periodically, disconnect machine from power source and check all electrical connections and components for broken or loose wires.

### MODEL #450A 230 V.A.C. — 50 Hz (Single input)

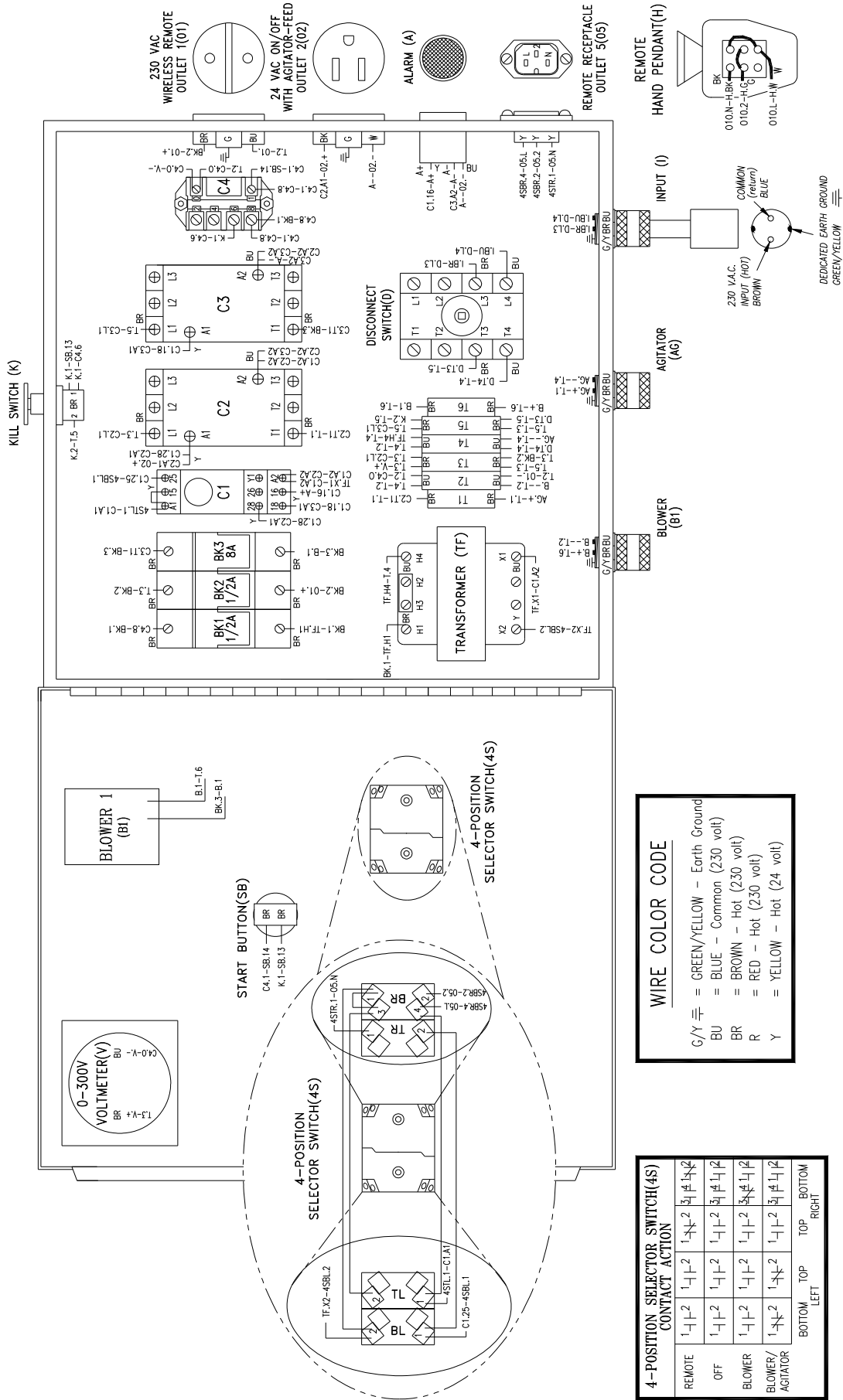

4-POSITION SELECTOR SWITCH(4S) CONTACT ACTION	TOP		BOTTOM	
	LEFT	RIGHT	LEFT	RIGHT
REMOTE	1-1-2	1-1-2	1-1-2	1-1-2
OFF	1-1-2	1-1-2	1-1-2	1-1-2
BLOWER	1-1-2	1-1-2	1-1-2	1-1-2
BLOWER/ ACTIVATOR	1-1-2	1-1-2	1-1-2	1-1-2

WIRE COLOR CODE	
G/Y	= GREEN/YELLOW - Earth Ground
BU	= BLUE - Common (230 volt)
BR	= BROWN - Hot (230 volt)
R	= RED - Hot (230 volt)
Y	= YELLOW - Hot (24 volt)

(illustration P)

**LADDER DIAGRAM**

**230 VOLT 50 HZ SINGLE INPUT**

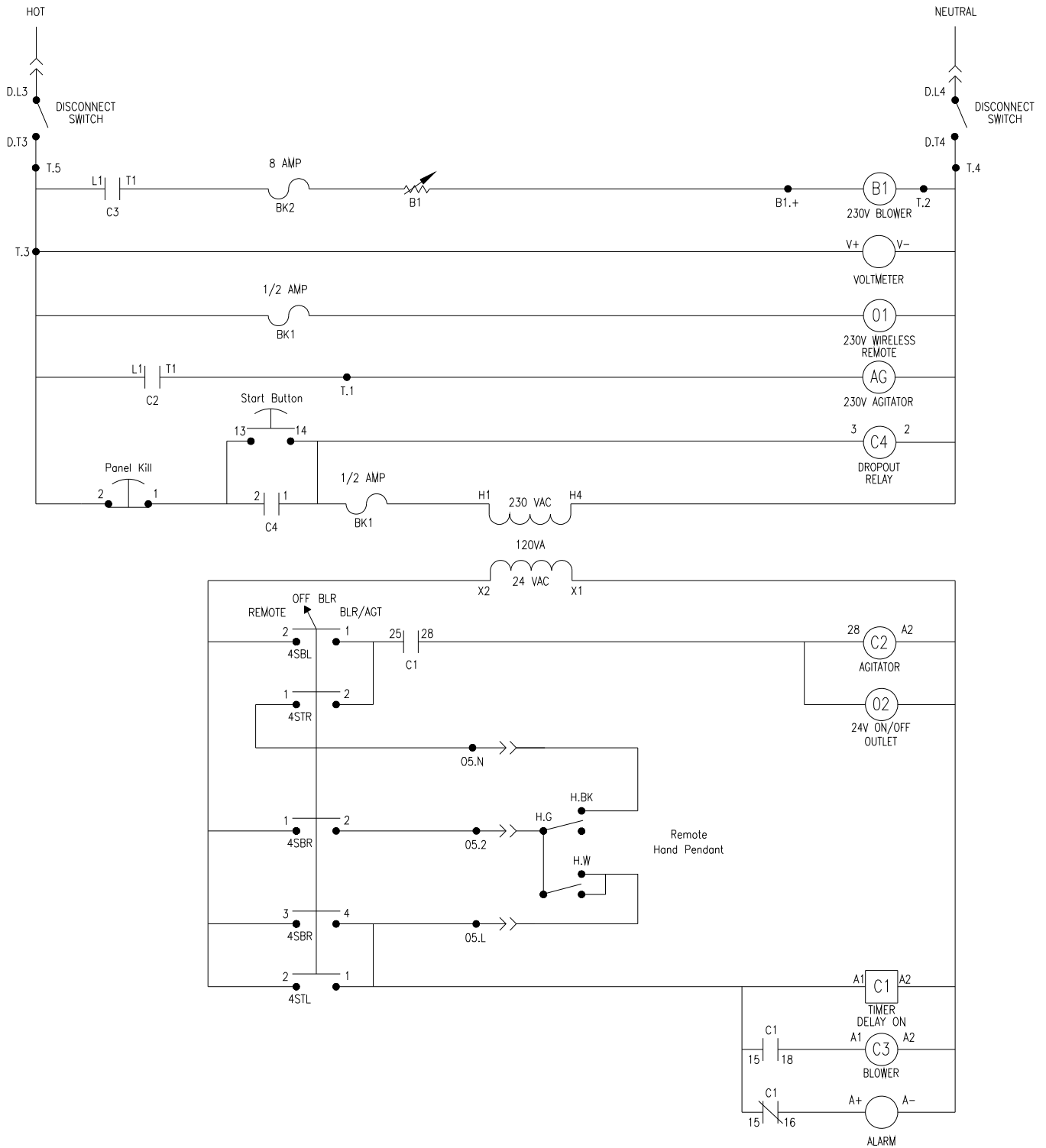

## TROUBLESHOOTING

### WARRANTY



This unit is backed by a warranty for manufacturer's defects. If machine needs service during that time, call your supplier immediately. **Do not** attempt to service, as this voids warranty.

### IMPORTANT



At any signs of trouble with your machine, stop immediately, disconnect power and call your supplier. Refer to *General Maintenance* section of this manual for further details. Always disconnect electrical power before making inspection or repairs.

## Mechanical Troubleshooting

### Problem

### Corrective Action

- |   |  |
|---|--|
| 1) Loud knocking sound.                         | A. Remove hopper and check machine agitators or airlock for foreign objects and remove.<br>B. Check and retention chains.  |
| 2) Poor output or uneven flow through the hose. | A. Gradually <b>increase</b> blower control setting and/or <b>close</b> slidegate until condition improves.<br>B. Check hose. Remove hose from airlock outlet and check for blocked material. Clean out by shaking hose. Connect hose to airlock, turn blower on high (no agitator/feed) for a few moments and try to free blockage.<br>C. Check insulation hose and blower hoses on machine for damage. Check connections. Tighten hose clamps to eliminate air leakage.<br>D. Check for misaligned agitator tines.<br>E. Try another electrical source. Use proper size wire for input power to correct low voltage condition.<br>F. Remove hopper, inspect airlock seals and plates for damage or wear. Refer to page 13 of <i>General Maintenance</i> and follow instructions for replacing seals. |
| 3) Too much dust on open blow.                  | A. <b>Reduce</b> air into system by decreasing blower control setting and <b>opening</b> slidegate.  |

## Electrical Troubleshooting

### IMPORTANT



Whenever power is interrupted to unit (i.e., unplugged, main disconnect switch off, kill switch depressed), power must be returned by correcting power interruption condition and pressing *green* start button.

### Problem

### Corrective Action

- |  |   |
|--|---|
| 1) Voltmeter showing no voltage <b>or</b> low voltage. | A. Turn Main Disconnect Switch to ON position.<br>B. Check input cord for proper connection to power source.<br>C. Check power source for proper voltage.<br>D. Remove lid from Main Control Panel and check voltage with multimeter at voltmeter terminals. Replace defective voltmeter. |
|--|---|

**Electrical Troubleshooting (cont.)**

- 2) Dropout relay **does not** engage.
- A. Check voltmeter. If no voltage, refer to #1 above.
  - B. Check power on input cord.
  - C. Check indicator tab on the top of the dropout relay. If tab is out, relay is not engaged. If tab is in, relay is engaged. (If tab is "in", refer to #3.)
- 3) Dropout relay **is** engaged (tab is "in"), but machine will not run.
- A. Check transformer breaker (BK1) with continuity tester.
  - B. Check secondary output of transformer (24volt). Replace if necessary
- 4) Machine does not function with hand pendant while 4-Position Selector Switch is in REMOTE mode.
- A. Check for proper start-up conditions as mentioned at beginning of this section. (See #2)
  - B. Be sure remote control cord is properly plugged into Main Control Panel.
  - C. Check remote control cord and hand pendant switch for damage or loose connections.
  - D. If neither Remote mode or Manual mode will function, check transformer breaker (BK1) with continuity tester.
- 5) Blower motor does not run, but drive motor does run.
- A. Check operation in remote mode and manual mode with 4-Position Selector Switch and remote hand pendant.
  - B. Check blower control for ON position.
  - C. Check for loose blower cord plug-in connection at drop cords from Main Control Panel.
  - D. Check blower motor. Manually unplug blower(s) and plug directly into a separate power source, (i.e., extension cord). Disconnect power supply and visually inspect system for defective, broken or loose wiring connections inside blower box.
  - E. Check blower breaker (BK2) in Main Control Panel with a continuity tester.
  - F. Check Blower Controls. Disconnect Blower Control wires on Main Control Panel door and reconnect the two power leads bypassing the Blower Control. (Blower will run full speed only.)
  - G. Visually inspect and/or replace blower relay (C3) inside Main Control Panel.
- 6) Blower motor does not run in manual mode. (4-Position Selector Switch.)
- A. Check wiring connections on Selector Switch contacts. (Located on back of Main Control Panel door.)
- 7) Blower motor running hot.
- A. Clean or replace Filter. Check inside machine for debris/insulation around blower. Blow out blower motor and surrounding area with compressed air.
  - B. Check material hose for blockage. A restriction in the material output hose will cause the blowers to run hotter than normal.
  - C. Check blower motor for proper operation. (i.e. bearings, armature, or worn brushes.)
- 8) Excessive arcing of brushes on blower motor.
- A. Blow out brush assembly area with compressed air to remove accumulation of dirt and debris.
  - B. Check blower motor for proper operation. (i.e. bearings, armature, etc.)
  - C. Replace brush assembly. (See page 15 and 16 of *General Maintenance*.)

**Electrical Troubleshooting (cont.)**

- 9) Motor/Reducer Drive does not run, but blower motor does run.
- A. Manual Reset on motor is tripped. Disconnect power supply to machine. Wait until motor cools, (approximately 15 minutes), and press button on machine to reset.
  - B. Check for loose plug-in connection at drop cords from Main Control Panel. If there is a good connection, unplug motor from back of Junction Box and plug directly into a separate power source (i.e., extension cord). You will need to remove or change motor plug, and connect directly to power supply. (check for proper voltage 230 volt)
  - C. Visually inspect and/or replace agitator relay (C2), inside Main Control Panel.
- 10) Motor/Reducer Drive running improperly or hot.
- A. Disconnect power. Check agitators and airlock for debris.
  - B. Low voltage. Try another electrical source. Use proper wire size for power input cords.
  - C. Check bearings, sprocket and chain for binding, failure, or drive system misalignment.
  - D. Remove vertical drive chain from airlock and upper agitators. Run motor/reducer drive and airlock assembly under power. Check amperage.
  - E. Make sure the voltage, cycle (hertz), phase (1 or 3), and direction of rotation is correct.
  - F. Replace motor and/or reducer.
- 11) Agitator or airlock feeder not turning.
- A. Check sprockets for missing key. Replace with 1/4" key.
  - B. Chain broken or off sprocket. Repair or replace.
  - C. Check gearbox for sheared key between motor and reducer.
- 12) Pre-alarm sounds too long or continues without activating machine.
- A. Pre-alarm relay C1 (relay with control adjustment), should be turned counterclockwise/left. This will reduce time duration of alarm.
  - B. Replace relay module.

**PARTS LIST**

The manufacturer recommends that all repairs be made at its own factory service center. Machine repair done by the manufacturer is warranted for 90 days on repair parts and workmanship.

If you choose to have repairs made elsewhere, we offer replacement parts that have been carefully inspected to insure they meet the specifications of the original part. Any disassembly and reassembly of the unit to replace the defective part must be done with care to insure proper fit and alignment. No warranty consideration will be extended on parts that appear to be mishandled. All units should be run for a few minutes without material to insure proper alignment. All questions regarding replacement of parts should be directed back to the factory.

**IMPORTANT:** Certain information is needed concerning your specific machine when ordering replacement parts:

- Machine Model number (i.e. Model #450A) • Serial Number
- Date Purchased
- Voltage of unit (main input): 120V or 230V (overseas) - single or double input
- Cycle: 50 or 60 hz. (U.S. and North American models are 60 hz.)  
(**Most** overseas units are 50 hz. Check invoice for correct cycle.)
- Blower size: large 3-stage 12.5 amp (6 amp overseas)  
or small 2-stage 8 amp (4 amp overseas)

If this information is not known, contact supplier with serial number of machine. This information is needed on mechanical parts as well as electrical components. (Due to mechanical adjustments that compensate for electrical requirements, the above information is needed.)

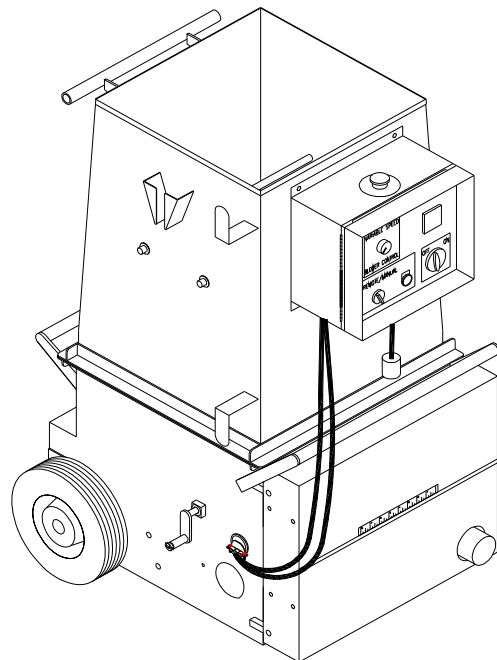

**MODEL #450A -- PARTS LIST**

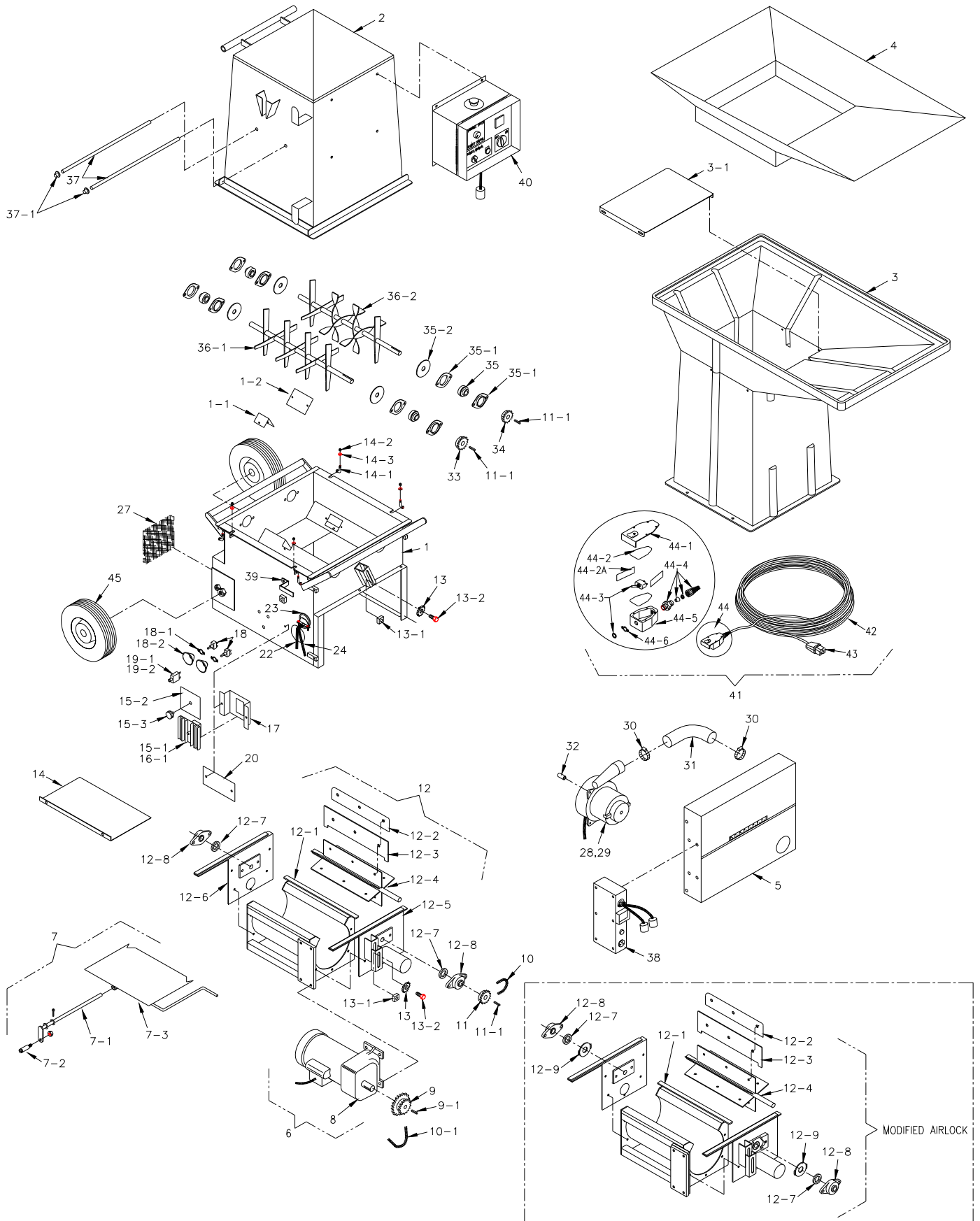

**MODEL #450A -- PARTS LIST**

<b>Item #</b>	<b>Part #</b>	<b>Description</b>
1	4501-A-R1	Base
1-1	4547	Plate, Baffle "V", 450A base
1-2	4548	Plate, Cover Straight, 450A
2	4502-A	Hopper f/150, 250A, 450A
3	4502-P	Plastic Hopper w>Loading Tray f/150, 250A, 450A
3-1	4502-B-7	Hopper Insert
4	2551	Loading Tray w/Hardware f/150, 250A, 450A
5	4503	Guard, Chain
6	42517-1B-B	Motor & Cord Assy, 1/2hp, T.E.F.C., 120V, 60 hz
6	42517-4A	Motor & Cord Assy, 1/2hp, 230V, 50 hz
7	4508-R1-A	Slidegate Assembly
7-1	4256-A	Crankrod w/Handle Bracket
7-2	4507	Handle, Crankrod
7-3	4508-R1	Slidegate
8	42517-3	Gearmotor, 1/2hp, 230V,50 hz
9	1024	Sprocket 15T x 24T x 3/4"
9-1	1556	Key 3/16" x 3/16" x 1 1/4"
10	590	Chain #40 x 25" (U.S.)
10	42524	Chain #40 x 26" (Overseas)
10-1	150517	Chain #40 x 47" (U.S.)
10-1	VH550-2	Chain #40 x 45" (Over Seas)
--	199	Link, Connector (Not Shown) (2)
11	4511	Sprocket, 15T x 3/4" (airlock)
11-1	448	Key 3/16" x 7/8" (3)
12	4512-R1	Airlock Assembly
12-1	4512-1-R1	Chamber, Airlock, 8" x 14"
12-2	4512-2	Plate, Top, Airlock, 14" (6)
12-3	4512-3	Seal, Airlock, 2-Ply, 14" (6)
12-4	4512-4	Rotor, Airlock
12-5	450A/OP.EP	Plate, End, Output, Airlock
12-6	450A/IP.EP	Plate, End, Input, Airlock
12-7	426-7	Seal, Felt, Airlock, 3/4" Bore (2)
12-8	426-6	Bearing, 2-Bolt Flange, 3/4" Bore (2)

**Modified Airlock**

12-1	4512-1E	Chamber, Airlock, 8" x 14"
12-2	4512-2E	Plate, Top, Airlock, 14" (6)
12-3	4512-3M	Seal, Airlock, Rhinohyde, 14" (6)
12-4	4512-4E	Rotor, Airlock
12-7	426-7	Seal, Felt, Airlock, 3/4" Bore (2)
12-8	426-6E	Bearing, 2-Bolt Flange, 3/4" Bore (Spec.) (2)
12-9	4512-7	Washer, Compression
12-10	RM-OTH100-MI	Roping, Airlock (not shown)

13	432	Sprocket, Idler, #40, 17T x 5/8" (2)
13-1	40052	1" x 1" Square Nut (2)
13-2	FSB120	SB 5/8" x 3/4" Shoulder Bolt

**MODEL #450A -- PARTS LIST**

<b>Item #</b>	<b>Part #</b>	<b>Description</b>
14	4514	Guard, Bottom Plate
14-1	2530-1	Latch Bolt (4)
14-2	FN014	N 5/16-18 Lock Nut-Crimped (4)
14-3	FW007	5/16" Flat Washer (4)
15-1	419-A	Blower Control, 120V, 60hz (units w/o ELU)
15-2	420-1	Cover, Blower Control (units w/o ELU)
15-3	420-2	Knob, Blower Control (units w/o ELU)
16-1	419-B	Blower Control, 230V, 50hz (units w/o ELU)
17	421	Bracket, Blower Control (units w/o ELU)
18	1536-3	Switch, Toggle (SPST) (units w/o ELU) (2)
18-1	1536-8	On/Off Plate (2)
18-2	1536-6	Guard, Switch (Cone) (2)
19-1	433-D	Manual Reset, 10 Amp, 120V, 60hz
19-2	433-B	Manual Reset, 5 Amp, 230V, 50hz
20	40051	Blower Control Cover Plate (units with ELU only)
22	12-3 SJ	Wire, #12-3 (SJ) x 75" (Motor) (U.S.)
22	12-3-SJ-M	Wire, #12-3 (SJ-M) x 75" (Motor) (Overseas)
23	121	Cord, Clamp 3/4"
24	14-3 SJ	Wire, #14-3 (SJ) x 62" (Blower) (U.S.)
24	14-3-SJ-M	Wire, #14-3 (SJ-M) x 62" (Blower) (Overseas)
27	42562	Filter, 6 1/4" x 6 1/4"
28	408-E	Blower Motor, 12.5 amp, 3-stage, 120V, 50/60hz
29	408-F	Blower Motor, 5.5 amp, 3-stage, 230V, 50/60hz
30	337	Clamp, Hose, 2" (2)
31	4549	Hose, 10"
32	409-D	Spacer, Blower, 2 1/2" f/3-stage blower (3)
33	428	Sprocket, 18T x 3/4", f/agitator
34	4511	Sprocket, 15T x 3/4", f/agitator (U.S.)
34	4511-A	Sprocket, 12T x 3/4", f/agitator (Overseas)
35	107-1	Bearing, 3/4" Insert Only (4)
35-1	1507	Housing, Flange, 2-Bolt 3/4" Stamped (8)
35-2	1506	Felt Washer, 3/4" Bore (4)
36-1	4541-A	Agitator, Left
36-2	4541-B	Agitator, Right (above airlock)
37	1510	Hopper Bar (2)
37-1	FN009	Push Nut, 1/2" (4)

**MODEL #450A -- PARTS LIST**

<b>Item #</b>	<b>Part #</b>	<b>Description</b>
		<b>OPTIONS</b>
38	392-A	Standard Remote Control Unit (120V/60hz D.I.) (Note: Remote Control Cord not included)
39	2531	Bracket, Cord Assy
40	ELU11-4546	Electrical Upgrade (230V/50hz) (single input, 3-stage blower) (See sub-assembly on page 29) (Note: Remote Control Cord not included)
41	395A-B	Cord, Remote Control Complete, 100' Style B (units with Standard Remote only)
41	ELU95-395A-D	Cord, Remote Control Complete, 100', Style D (after 7-1-96 units with ELU only)
42	1541	Cord, #18-3 (SJ) x 100 ft.
43	126-B	Plug, NEMA# 6-15P Style B
43	543-M-8	Plug, #509-1215 Style D (after 7-1-96 units with ELU only)
44	1536	Hand Pendant, Remote Control Complete f/Style B
44	1536-A	Hand Pendant, Remote Control Complete f/Style D
44-1	1536-1-A	Cover, Switch w/Belt Clip & Guard f/Hand Pendant
44-2	1536-2	Insulator (2)
44-2A	1536-2A	Insulator Strip (2)
44-3	109066-9	Switch, Toggle/DPDT (after 7-1-96 units with ELU only)
44-3	1536-3	Switch, Toggle/SPST (units without ELU only)
44-4	1536-4	Cord Restraint, 3/8"
44-5	1536-5	Housing, Switch
44-6	1536-8	On/Off Plate, (units without ELU only)
45	4520-1	Wheel, 10" (2) (Hard)

## MODEL #450A -- ELECTRICAL PARTS LIST

### 230 V.A.C. 50 Hz.

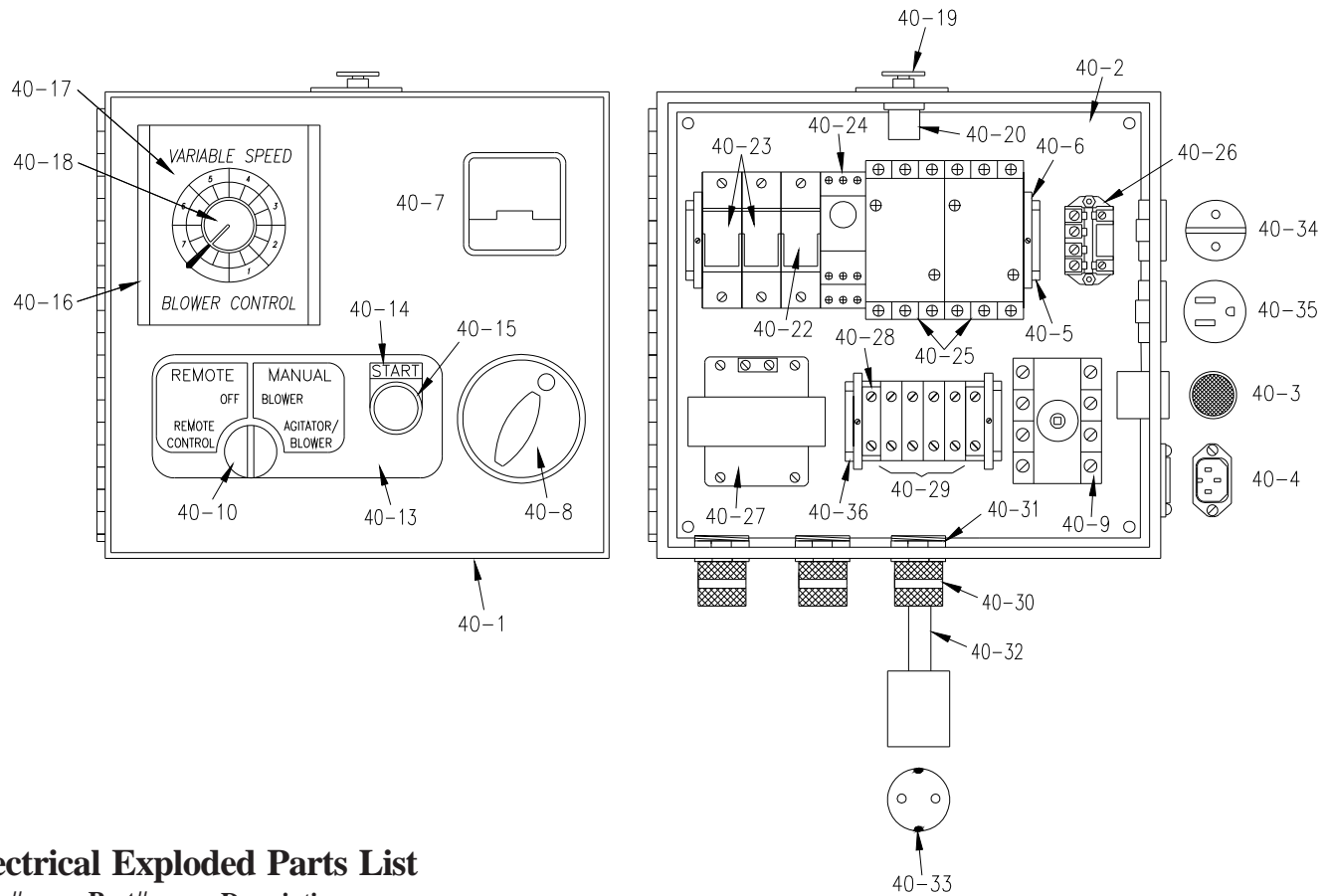

### Electrical Exploded Parts List

Item#	Part#	Description	Item#	Part#	Description
40-1	1557-R2	Box, Electrical 11" x 13" x 7"	40-19	508-2	Switch, Kill
40-2	1565-R1	Plate, Backing for Electric Box	40-20	8075-1	Contactor, Kill Switch
40-3	543-M-38	Alarm for Pre-Alarm System, 24V	40-22	BRKR-8	Breaker, 8 AMP
40-4	543-M-2	Receptacle, RC Plug #509-1050 (remote)	40-23	BRKR-.5	Breaker, 1/2 AMP (2)
40-5	ELU07-C	1 3/8" Dinrail, 8 1/2" Long	40-24	ELU06-6	Timer, 24 VAC
40-6	151080-49	Clamp, f/ 1 3/8" Din Rail (4)	40-25	ELU11-5	GE Contactor / Relay 25 Amp (2)
40-7	1531-B	Voltmeter, 0-300V	40-26	ELU10-12	Relay, E-MECH, CTRL-V230, DPDY-NO (2)
40-8	54-M-33-OS	Operator Handle Assembly	40-27	ELU06-10	Transformer 2A
40-9	543-M-33-D	Switch, Disconnect 40A #XA324BY	40-28	151080-61	Terminal Block, Small
40-10	543-M-22	Switch, 4-position Selector	40-29	151080-62	Terminal Block, Large (4)
40-11	543-M-15	Contact Block , Selector Switch (white) #KA-1 (not shown)	40-30	543-M-17	Connector, Cord, Liq. Tite, 1/2" Blue (3)
40-12	543-M-16	Contact Block , Selector Switch (red) #KA-3 (3) (not shown)	40-31	391N-A-3	Locknut, Steel, Conduit, 1/2" (3)
40-13	KMC-068	Decal, (Remote/Manual - 4-Position)	40-32	12-3-SJ-M	12-3 SJ w/Brown/Blue/Green/Yellow
40-14	543-M-60	Start Legend Plate	40-33	ELU06-9	Plug, European
40-15	543-M-59	Switch, Pushbutton On	40-34	543-M-78	Socket, Schuko, 16A Cover Panel
40-16	419-B	Blower Control (230V, 50Hz.)	40-35	1544	Receptacle, NEMA# 5-15R
40-17	420-1	Cover, Blower Control	40-36	ELU07-F	1 3/8" Dinrail, 2 3/4" Long
40-18	420-2	Knob, Blower Control	40-37	ELU10-13	Cover, E-MECH Relay (not shown)
			40-38	ELU06-1	Cover, Transformer (not shown)

## GLOSSARY

<b>BRIDGING</b>	A tendency for fiber to cling in the hopper forming an air pocket above the airlock. This hinders the normal feeding process of the machine.
<b>CFM</b>	(Cubic feet per minute). A measurement of volume or <b>quantity</b> of air flowing at a certain rate, or air moving capability, of a blower. It is the volume of air moved per minute. Higher volume provides increased coverage and velocity of fiber as it leaves the hose.
<b>CHECK VALVE</b>	A valve that allows air to flow in one direction only. When mounted on the outlet of the blower, it protects the blower from fiber contamination through the air hose when using one blower. When the blower stops, the valve closes.
<b>COMMERCIAL SPRAY-ON</b>	The application of fiber with adhesive to a surface which will remain exposed. The application must therefore be impacted in a smooth, uniform manner.
<b>COVERAGE</b>	Refers to the amount of fiber coverage, usually measured in square feet, according to the R-value desired. This information is given on the fiber package.
<b>NEW CONSTRUCTION WALL CAVITY SPRAY</b>	The spray application of fiber with water or adhesive into an exposed wall cavity to later be covered with drywall sheathing, etc.
<b>PSI</b>	Pounds of pressure per square inch of <b>force</b> exerted on a surface by air or liquid. High-pressure blowers push the fiber through the hose. Higher pressure provides less hose plugging and increased compaction in side wall.
<b>PRODUCTION RATE</b>	Pounds of fiber blown per hour.
<b>RPM</b>	(Revolutions per minute). Speed at which the shaft of a rotating device (i.e. blower fan, agitator) is moving.
<b>R-VALUE</b>	Resistance value. A precise measurement of the insulation's resistance to heat transfer. The higher the resistance value, the slower the heat will transfer through the insulating material.
<b>RETRO-SIDEWALL</b>	This refers to the installation of fiber into an unexposed wall cavity. Fiber is usually installed through holes drilled into the exterior siding.
<b>SETTLED DENSITY</b>	The point at which the fiber will not continue to settle further. Any insulation blown will have a certain amount of progressive settling that occurs over a period of time. Following the fiber manufacturer's recommendations for bag rate coverage will provide useful information to accommodate for settling.
<b>SETTLING</b>	Compression or compaction of insulation fibers caused by the weight of the material, vibration of structure, temperature, and humidity cycles.

**SERVICE RECORD**

DATE	MAINTENANCE PERFORMED	COMPONENTS REQUIRED