

KRENDL

Fiber Moving Equipment



OWNERS MANUAL GV100



50 YEARS OF QUALITY AND SERVICE

KRENDL MACHINE COMPANY • 1201 SPENCERVILLE AVE
DELPHOS, OHIO 45833 • TELEPHONE 419-692-3060 • FAX 419-695-9301
E - MAIL: krendl@krendlmachine.com • WEB SITE: www.krendlmachine.com

CONGRATULATIONS ON YOUR PURCHASE OF KRENDL EQUIPMENT

**MODEL GV100
OWNER'S MANUAL**

FOR ASSURED SAFETY AND CONFIDENCE, PLEASE READ THIS MANUAL CAREFULLY BEFORE INSTALLING AND OPERATING YOUR MACHINE.

**E-MAIL ADDRESS IS: krendl@krendlmachine.com
WEB SITE IS: www.krendlmachine.com**

Table of Contents

Preface	1
General Safety Information	1
Decals	3
Returned Goods Procedure	4
Service	4
Warranty	5
Basic Components	6
Theory of Operation	6
Operating Instructions	7
Machine Hook-up	7
Machine Start-up	8
Machine Shutdown	8
Trouble Shooting	8
Maintenance	9
Fan Removal for Replacement	11
Fan Installation for Replacement	11
Exploded Parts List	12

Thank you for purchasing **KRENDL FIBER MOVING EQUIPMENT**. With over fifty years experience in manufacturing fiber moving equipment, we have designed and built your equipment with the highest quality to provide years of reliable service.

This manual has been prepared to help you obtain the maximum efficiency and service from your Krendl equipment. The machine is designed to move fibers with the utmost in dependable performance. Our primary objective is to build equipment which will provide complete satisfaction.

Since Krendl Machine Company does not manufacture or sell fibers, our interest lies only in the proper performance of the equipment we manufacture. We make no recommendations or guarantees concerning various fibers.

CAUTION:



This manual contains important information regarding the **safe** assembly and operation of your machine. We urge you to read it carefully and follow the instructions provided. If your questions are not answered in this manual, please contact us? We want you to be able to operate this unit safely and confidently.

FILL IN AND RETAIN:

Krendl Machine Company
1201 Spencerville Ave.
Delphos, Ohio 45833 U.S.A.

Telephone: 419-692-3060
Fax: 419-695-9301
E-mail: krendl@krendlmachine.com
Web Site: www.krendlmachine.com

For your protection in the event of theft or loss, please fill in the information requested for your own records. This information will be needed for warranty repairs. You may also want to attach a copy of your invoice.

Machine model number _____

Serial number _____

Date of purchase _____

Supplier / Distributor _____

General Safety Information



Important: Read **all** instructions **before** operating this equipment. This equipment can be potentially dangerous and must be used in strict accordance with instructions.



Disclaimer Notice: The manufacturer will not be legally responsible for any injury or damage resulting from the improper use of this equipment or the failure to follow instructions.



General Safety

- Read this manual carefully and become familiar with your equipment. Know its applications, limitations, and any operational hazards.
- This equipment was designed and manufactured for specific applications. Do not attempt to modify the unit or utilize it for any application in which it was not intended. If you have any questions about your intended use or the machines suitability, ask your supplier/distributor or consult the factory. Krendl Machine Company can not anticipate every circumstance that might involve a hazard. For that reason, warnings in the manual and warning tags and decals affixed to the unit, are **not** all-inclusive. Do not handle, operate, or service the unit by a procedure or method not specifically recommended by the manufacturer.



Electrical Safety

- The **National Electric Code (NEC)** in the United States and many international electrical codes require frame and external electrically conductive parts of this machine to be properly connected to an approved earth ground. Local electrical codes may also require proper grounding of machine. Consult with local electricians for grounding requirements in your area.
- Take care and follow these instructions when removing or installing the battery or electrical burn could occur. When removing battery, disconnect negative cable first followed by positive cable. When installing battery, connect positive cable first followed by negative cable.
- Reference NFPA 79, 70E, or OSHA safe work practices when performing energized work procedures.



Safety/Caution

- **Be Safe** - **ALWAYS** remove key from ignition before performing any maintenance or service to vacuum.
- **Be Safe** - Keep away from moving parts.
- **Be Safe** - Make sure all guards are in proper place **before** operating machine.
- **Be Safe** - Do not remove safety pins located in output tube, as injury may result.
- **Be Safe** - Do not remove fan chamber cover when unit is in the **on** position.
- **Be Safe** - Do not use vacuum to move stones, nails, or any other foreign debris.
- **Be Safe** - Consult a qualified technician to answer questions **before** attempting to service unit, as injury may result.
- **Be Safe** - Wear an **approved** dust mask or respirator for operator comfort and protection.
- **Be Safe** - Use proper and secure clamping method for all fiber hoses to prevent uncontrolled fiber stream bursts around operator.



Make Sure!

- Vacuum is sitting on level surface.
- Both inlet and outlet hoses are attached and secured with hose clamps before operating.
- Fan chamber is empty of foreign debris **before** starting as this can bind and stall your machine or damage the fan.
- Fan chamber cover is in place and properly secured before turning vacuum on.
- Vacuum is turned off **immediately** if hose is plugged.
- Vacuum is turned off **immediately** if there is excessive vibration as the fan may be out of balance.



Rotating fan can be dangerous! Clothes, hair, hands, etc. can get sucked into vacuum chamber. Properly attach hoses before operation. Failure to do this could cause serious injury or death.



Rotating parts can be dangerous! You can snag clothes, skin, hair, hands, etc. This can cause serious injury or death.



Manufacturer information is provided here.



During operation, this area of machine is hot! Be careful not to touch. This can cause serious burns.

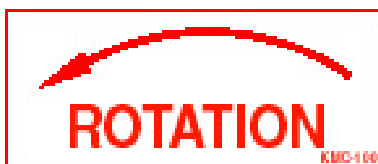

Rotating parts will be moving in this direction.



Part number for identification and tracking.



Indicates which employee inspected equipment and on what date.

Returned Goods Procedure

IF MACHINE WAS NOT PURCHASED DIRECTLY FROM KRENDL MACHINE COMPANY, CONTACT YOUR SUPPLIER / DISTRIBUTOR.

When returning products to Krendl for repair, first obtain a return goods authorization, at which time you will be given shipping instructions. The product must be shipped **PREPAID**:

Krendl Machine Company

1201 Spencerville Ave.

Delphos, Ohio 45833 U.S.A.

Telephone: 419-692-3060

Fax: 419-695-9301

E-mail: krendl@krendlmachine.com

Web Site: www.krendlmachine.com

Once the unit is received, it will be inspected. In-warranty units will be repaired and returned immediately. An estimate of repair charges will be provided for out-of-warranty units.

Service

See an Authorized Briggs & Stratton Service Dealer. Each one carries a stock of Genuine Briggs & Stratton Parts and is equipped with special service tools. Trained mechanics assure expert repair service on all Briggs & Stratton engines. Only dealers advertising as “Authorized Briggs & Stratton” are required to meet Briggs & Stratton standards.

You may locate your nearest Authorized Briggs & Stratton Service Dealer in our dealer locator map on our web site www.briggsandstratton.com or your local phone directory under “Engines, Gasoline” or “Gasoline Engines,” or “Lawn Mowers” or similar category.

WARRANTY

Krendl Machine Company (Company) warrants to each original purchaser (Buyer) of its equipment or accessories that such products will be free of manufacturing defects for a period of 12 months from the date of shipment to the Buyer.

No warranty is made with respect to:

1. Components or accessories manufactured and warranted by others. Warranties for purchased component parts as supplied from vendor such as engine, electric motor, blower, gearbox, transmission, etc., if furnished by the manufacturer of the component, are on file at the Company's main office and copies will be furnished at request of Buyer. Component(s), shipping costs prepaid, shall be sent to Company who in turn shall forward to vendor for evaluation and warranty determination.
2. Any defect caused by repair, alteration and/or adjustment performed by Buyer or customer/vendor of Buyer without the express written authorization of the Company.
3. The labor costs of replacing parts by parties other than the Company.
4. Any machine that has not been operated and / or maintained in accordance with normal industry practice and the written recommendations of the Company. (e.g. machine operated with an improperly sized, worn or damaged hose, improper or inattention to preventative maintenance, etc.)
5. The product has been subjected to misuse, negligence or accident or results of any application or use of the blowing equipment not in accordance with the Company recommendations.

This limited warranty does not cover the free replacement of component parts that become inoperative due to wear and usage and need to be replaced on a regular basis, including but not limited to: airlock seal(s), agitator(s), shredder(s), auger(s), fuse(s), switch(es), clutch(es), hose(s), shaft seal(s), chain(s), belt(s), sprocket(s), pulley(s), bearing(s), cable(s), battery(ies), filter(s), fan(s), etc.

The Company's obligation under this warranty is limited to repairing or replacing (at Company option) any part that is determined by the Company to be suffering from a manufacturing defect. The Company (at Company option) will provide any required parts and labor to the Buyer. If the equipment or parts must be returned to the Company for repair, all transportation costs shall be the Buyer's responsibility.

This limited warranty is expressly in lieu of any other guarantees and / or warranties, oral or written, expressed or implied, including without limitation, the implied warranty of merchantability. No warranty, express or implied, other than the aforesaid warranty is made or authorized by Company. Company shall not be liable for any direct, indirect, incidental or consequential damages to property or injury to any person or costs associated with loss of production resulting in loss of revenue, profits or loss of equipment through the use of this equipment.

Note: Special job circumstances incurring costs for specialized repair and next day delivery of parts will not be reimbursed by the manufacturer unless authorized by factory.

Basic Components

This is a view of the basic components of your machine. It shows the location of each item and gives the function of each. Use this as a guide throughout the manual. (See Illust. A)

- A) **STAND**—Mobile frame unit that supports the motor, battery, and fan chamber.
- B) **ENGINE**—Provides power to the fan.
- C) **FAN**—Unit that produces air current or vacuum.
- D) **FAN CHAMBER**—Protective housing that provides an enclosed air space for the fan to create a vacuum.
- E) **FAN CHAMBER COVER**—Provides access to the fan for general maintenance.
- F) **BATTERY**—Supplies power for the electric start on the engine.
- G) **HOUR METER / TACHOMETER**—Monitors the use and speed of the engine. (**Note:** LUBE/CHG OIL will flash every 25 hours) (Not Shown)

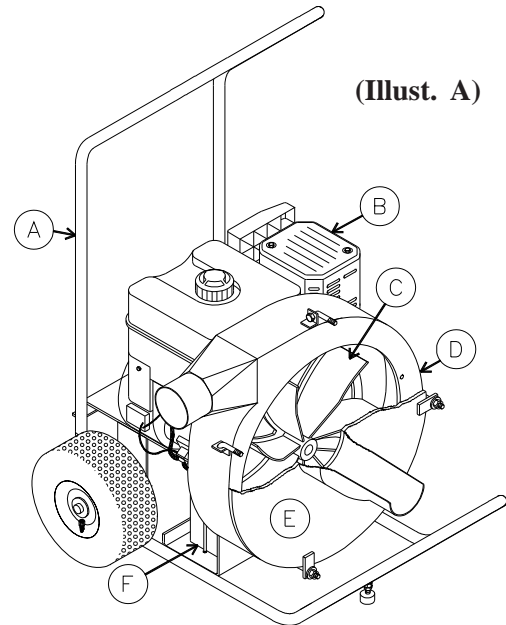

Theory of Operation

This unit is designed to move all recycled and new fiber materials from the job site and deliver them directly to a designated area such as a filter bag, vacuum hopper, etc. (See Illust. B)

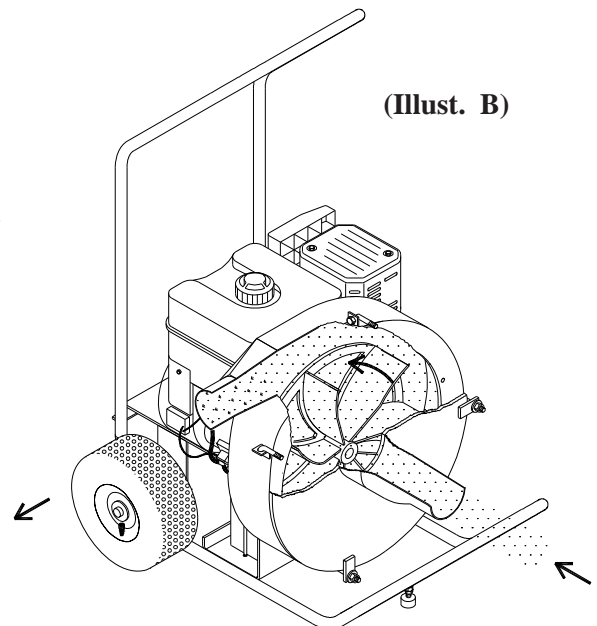

A common application for this unit is the vacuum hopper system. Once the fiber material has been deposited into the hopper, the air passes through the perforated mesh screen in the vacuum hopper, where it is filtered, and exhausted. (See Illust. C on page 6.)



Machine Hook-up

This unit comes ready for connection to the model VH550 (vacuum hopper) and VH550-B (vacuum hopper). **Note: A bin level indicator and blastgate are not used with the model VH550 (vacuum hopper).**

This unit provides a direct connection to a 4" insulation hose. Slide hose on to the inlet and outlet of the gas vacuum and secure with hose clamps. **Note: Hose clamps are to be utilized with all hose connections to prevent air leakage and insure operator safety. Correct use of clamps also helps to prevent hose plugging.**

-  1.) **For hook-up to the VH550 (vacuum hopper) only.** Connect hose from gas vacuum outlet to vacuum hopper inlet. Slide hose on to the gas vacuum inlet. Secure all hose connections with hose clamps. (See Illust. C)
-  2.) **For hook-up to the VH550-B (vacuum hopper) only.** Connect hose from gas vacuum outlet to vacuum hopper inlet. Connect hose from gas vacuum inlet to blastgate outlet. Connect hose to the blastgate inlet. Secure all hose connections with hose clamps. (See Illust. C)

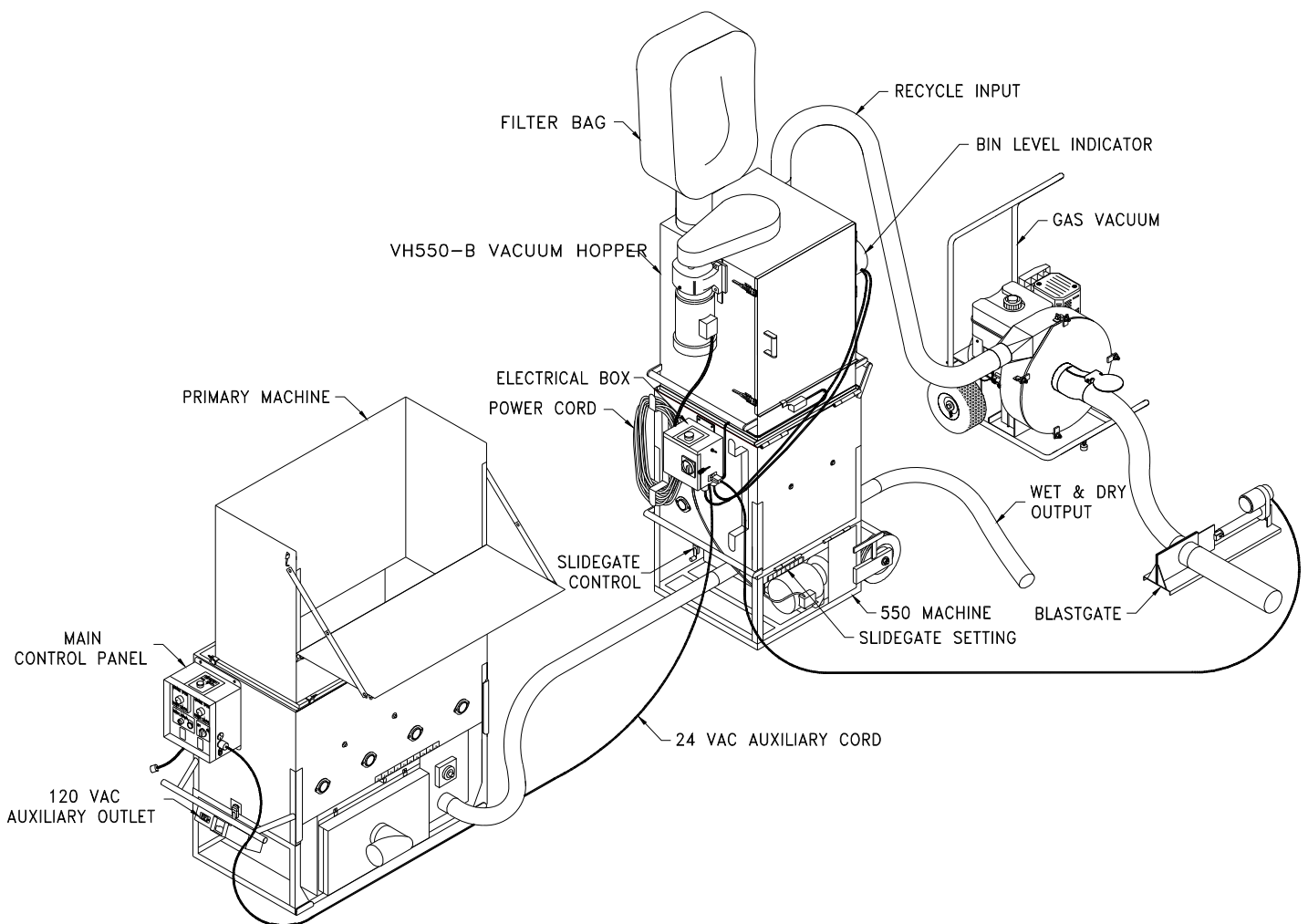

(Illust. C)

 At all times keep your hands, clothing, foreign objects, etc. away from inlet and discharge of your gas vacuum.

 Never operate vacuum without hoses attached.

 **Note: The end user should perform a risk assessment when first using this equipment. The end user has knowledge of conditions the equipment is used in. Therefore, the end user can ensure that necessary control measures be implemented before equipment use. (Follow all local, state, federal, and/or DSEAR requirements.)**

Machine Start-up

- 1.) Place vacuum on level surface.
- 2.) Hook up hoses to the inlet and discharge, secure with clamps before operation.
- 3.) Move choke control to choke position.
- 4.) Move throttle control to fast position.
- 5.) Turn fuel shut-off valve on.
- 6.) Turn key to start position (repeat until engine starts).
- 7.) Move choke control to off position after start up.
- 8.) Move throttle to appropriate operating speed.



Machine Shutdown

- 1.) Allow plenty of time for insulation hose to empty.
- 2.) Move throttle control to slow position (give the fan time to slow down).
- 3.) Let engine cool down for 2 minutes before shutting off.
- 4.) Turn key to off position and remove from switch.
- 5.) Close fuel shut-off valve. **Note: If fuel shut-off valve is not closed, leakage may occur especially when transporting unit.**

See Briggs & Stratton operation manual for additional starting and stopping instructions.

Trouble Shooting

TROUBLE SHOOTING

Note: Whenever vacuum chamber cover is off, make sure key is taken out of the ignition switch.

Problem	Corrective Action
1) Gas vacuum will not start.	<ul style="list-style-type: none">• Check engine oil level - (if low, unit will not start).• Check engine fuel level.• Make sure there is no foreign debris in the fan chamber impeding the motion of the fan.• Battery is low or dead. Manually start vacuum with rewind starter. If vacuum runs, battery may need charged or replaced. If the battery is ok, electric starter may need serviced. (See Briggs & Stratton operations manual.)• Make sure spark plug wires are attached.• Make sure fuel shut off valve is open.

Problem

Corrective Action

- | | |
|--|---|
| 2) Excessive vibration. | <ul style="list-style-type: none">• Make sure spark plugs are sparking. If plugs do not spark make sure they are clean and the correct plug for the appropriate engine is used. (See Briggs & Stratton operations manual.) |
| 3) Loud knocking. | <ul style="list-style-type: none">• Make sure unit is sitting on a level surface.• Make sure fan is properly secured to motor shaft.• Check fan for damaged fins.• Make sure there is no excessive fiber build up on the fan and in the fan chamber.• Fan may be out of balance and need replaced.• Loose bolts on fan chamber cover. |
| 4) Gas vacuum loses horsepower. | <ul style="list-style-type: none">• Make sure fan is properly secured to motor shaft.• Make sure there is no foreign debris or fiber build up in the fan chamber. |
| 5) Gas vacuum engine is stalling, smoking, or running irregularly. | <ul style="list-style-type: none">• Make sure there is no debris in fuel tank and fuel filter. Clean and replace if necessary.• Make sure there is no excessive fiber build up on the fan and in the fan chamber.• Make sure air filter is clean, replace if necessary. |
| | <ul style="list-style-type: none">• Check engine fuel level - (Low fuel or no fuel).• Make sure fuel shut off is completely open.• Make sure gas vacuum is setting on level ground.• Improper fuel may have been used. Use lead free gasoline with a minimum of 85 octane. Do not use gasoline which contains Methanol. This will deteriorate the fuel line. Refer to owners manual.• Check for corrosion, build up, or foreign debris lodged in the float, pin, or seat. This would cause inadequate performance. (See your Briggs & Stratton dealer.)• Make sure engine oil level is not overfilled.• Make sure air filter is clean, replace if necessary. |

Maintenance

Periodic preventive maintenance will add years of life to your equipment. Reviewing the information in this manual will go a long way in reducing downtime and lost income.

See Briggs & Stratton operation manual for additional engine maintenance instructions and illustrations.

Krendl Machine Maintenance:

Daily

- Clear insulation away from engine to avoid fire, ensure proper ventilation, and reduce the chance of insulation getting in the fuel tank.

Weekly

- Remove air filter and blow with compressed air.
- Clean out fan chamber. Remove fiber build up on fan and inside of chamber.
- Verify torque ratings on capscrews of taper lock bushing to be 192 inch pounds.
- Inspect fan for wear and bent blades.

Note: Do not remove fan for general maintenance.

Monthly

- Check fuel tank and filter for debris and clean if necessary.

Quarterly

- Check and/or replace spark plugs.

Engine Maintenance:

First 5 Hours

- Change oil (SAE SYNTHETIC MOTOR OIL 5W-30)

Every 8 Hours or Daily

- Check oil level
- Clean around muffler, springs and linkages

Every 25 Hours or Every Season

- Change oil (SAE SYNTHETIC MOTOR OIL 5W-30) if operating under heavy load or high ambient temperature
- Hour/Tachometer will flash LUBE/CHG OIL every 25 hours
- Service air cleaner pre-cleaner*

Every 50 Hours or Every Season

- Change oil (SAE SYNTHETIC MOTOR OIL 5W-30)
- Clean and inspect spark arrester, if equipped
- Replace fuel filter**
- Clean cooling system*

Every 100 Hours or Every Season

- Service air cleaner cartridge*
- Replace spark plug

* *Clean more often under dusty conditions, or when airborne debris or chaff is present.*

** *If equipped with gaseous fuel in-line filter, follow equipment manufacturers recommended maintenance.*

Fan Removal for Replacement:

1. Remove fan chamber cover. (See Illust. D)
2. Remove cap screws and insert them in tapped holes in bushing flange.
3. Tighten cap screws progressively in a clockwise rotation placing equal amounts of torque until bushing disengages.
4. Remove fan from engine shaft.

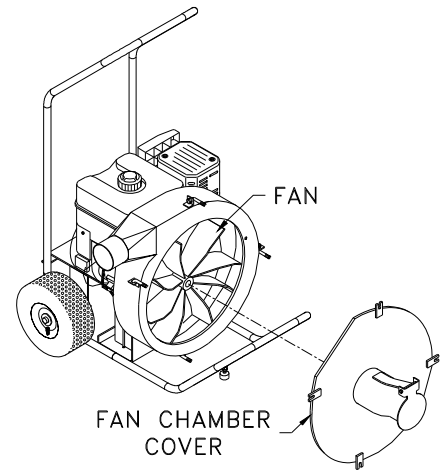
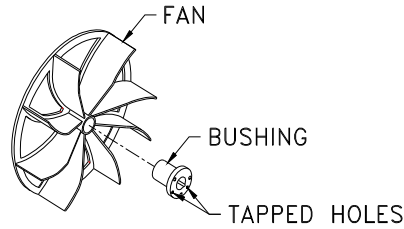

(Illust. D)

Fan Installation for Replacement:

1. Be sure the tapered cone surfaces of the bushing and the inside of the fan are clean and free of anti-seize lubricants.
2. Place bushing loosely into hub on fan. (See illust. E)
3. Start capscrews by hand, turning them just enough to engage the threads. **Note: Do not use a wrench at this time. Do not use anti-seize lubricant on tapered cone surfaces or on bolt threads when mounting fan to engine shaft.**
4. With key in shaft keyway, slide fan and bushing on to engine shaft. **Note: Make sure fan blades are facing outward and that the bushing is seated against the back step of the engine shaft.** (See Illust. F)
5. Tighten capscrews progressively with a wrench in a circular direction to ensure equal tension as fan draws down on shaft to achieve 192 inch pounds torque. **Note: Do not attempt to pull bushing flange flush with hub end; some gap must remain between flange and hub after tightening.**
6. Install fan chamber cover and secure with bolts. (See Illust. D)

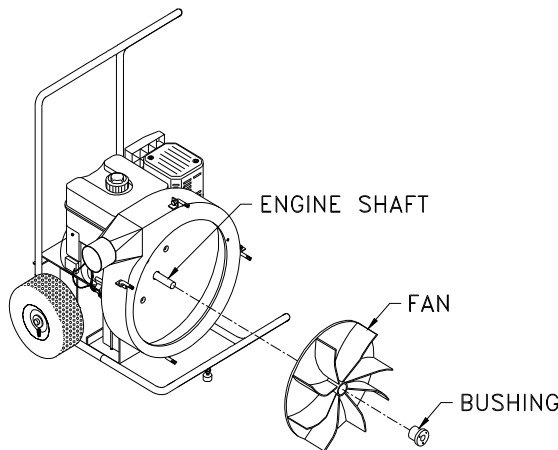

(Illust. E)

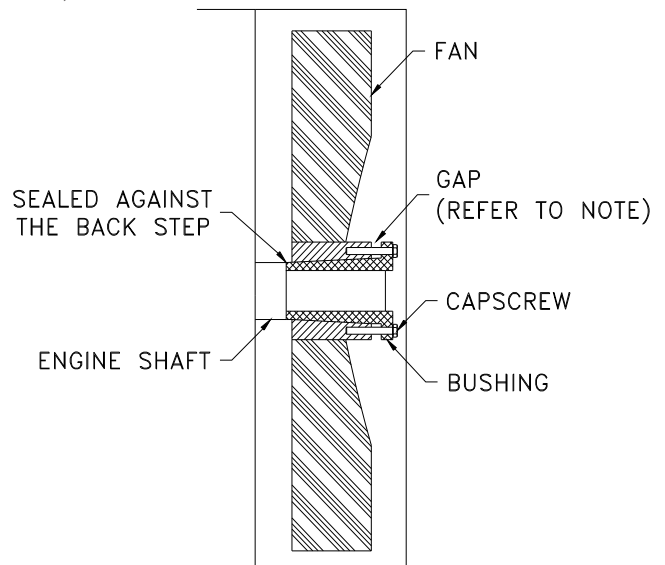

(Illust. F)

GV100 Exploded Parts View

GAS VACUUM

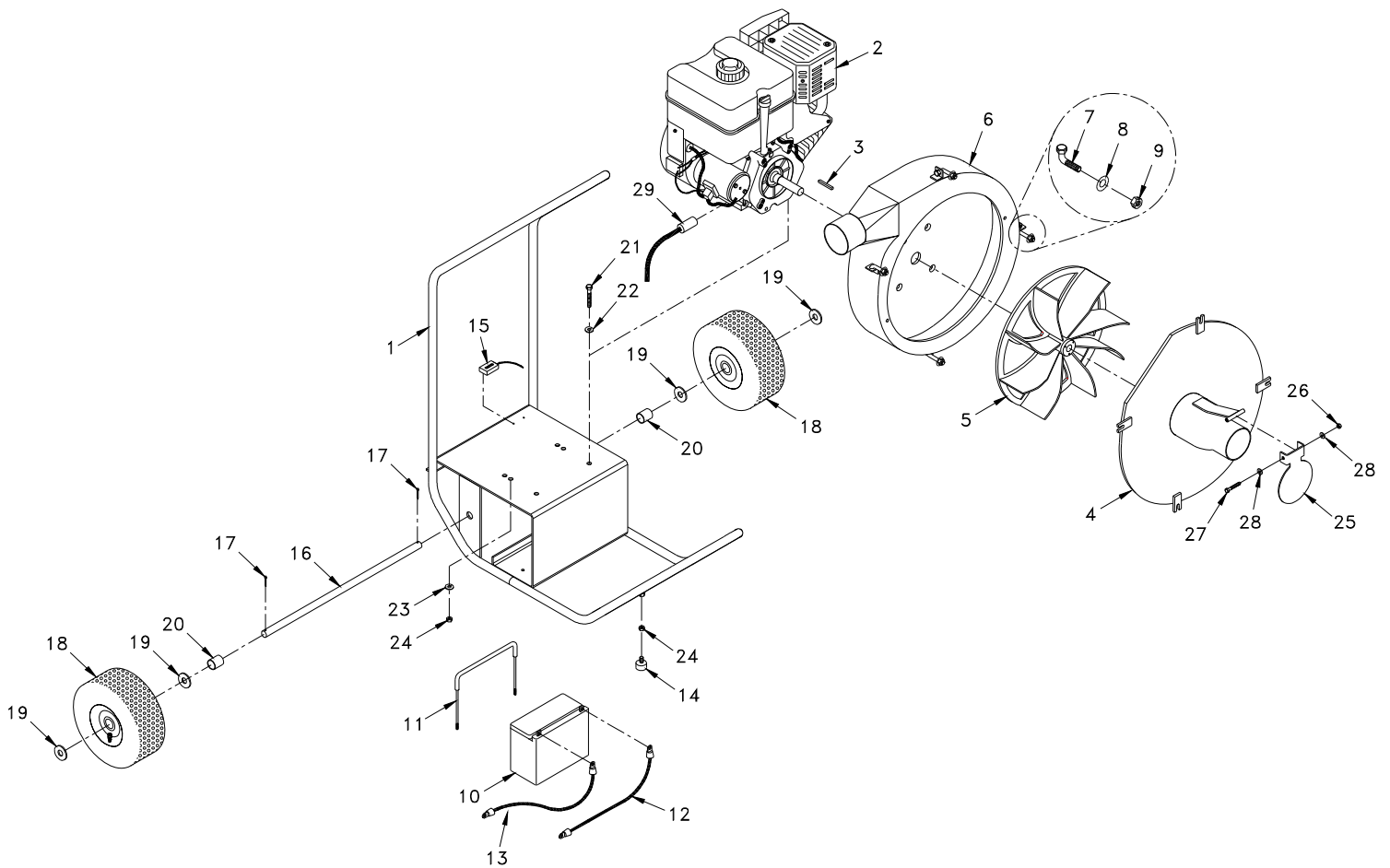

Item#	Part#	Description	Item#	Part#	Description
1	GV180-1	Gas Vacuum Stand	17	FSB078	Pin, Cotter, 1/8" x 1" (2)
2	GV100-5	Motor, Gas Vacuum, 13HP	18	W-11	Wheel, 11", Pneumatic (2)
3	150311	Key, 1/4" x 1/4" x 1 3/4"	19	FW030	3/4" Flat Washer-SAE (4)
4	GV100-4	Cover Plate, Fan Chamber	20	GV180-7	Wheel Spacer (2)
5	GV100-3-R1	18" Fan f/Gas Vacuum, Spoked	21	FSB164	SB 3/8 - 16 x 2 HMS (4)
6	GV100-2	Chamber, Fan, Gas Vacuum	22	FW005	3/8 Flat Washer (4)
7	GV100-10	Latch Bolt, 3" Bent (4)	23	FW006	3/8 Lock Washer (4)
8	FW011	7/16" Flat Washer (4)	24	FN016	N 3/8 - 16 Nut (5)
9	FN024	7/16" Nylon Lock Nut (4)	25	GV100-18	Guard, Inlet
10	GV100-13	Battery	26	FN005	N 1/4-20 Lock Nut-Crimped
11	GV100-14-A	Hold Down, Battery	27	FSB067	SB 1/4-20 x 3 1/4" HMS
12	GV100-15-R1	Battery Cable, Black, 13 1/4"	28	FW003	W 1/4" Flat Washer (2)
13	GV100-16-R1	Battery Cable, Red, 8"	29	4000-27/28	Drain Valve, Hose & Cap Kit
14	GV100-8-R1	Vibration Isolater, Cart	30	FSB139	SB 7/16 - 14 x 1 1/4" FHSCS (4) (Not Shown)
15	GV100-11	Hour Meter			Note: Bolts connect the chamber to the motor.
16	GV180-7	Wheel Axle			



50 YEARS OF QUALITY AND SERVICE

Made in the U.S.A.

**KRENDL MACHINE COMPANY • 1201 SPENCERVILLE AVE
DELPHOS, OHIO 45833 • TELEPHONE 419-692-3060 • FAX 419-695-9301
E - MAIL: krendl@krendlmachine.com • WEB SITE: www.krendlmachine.com**
