

## 12V INTERNAL WETTING SYSTEM CONTROL MODULE

PART#: 367C-D-CM

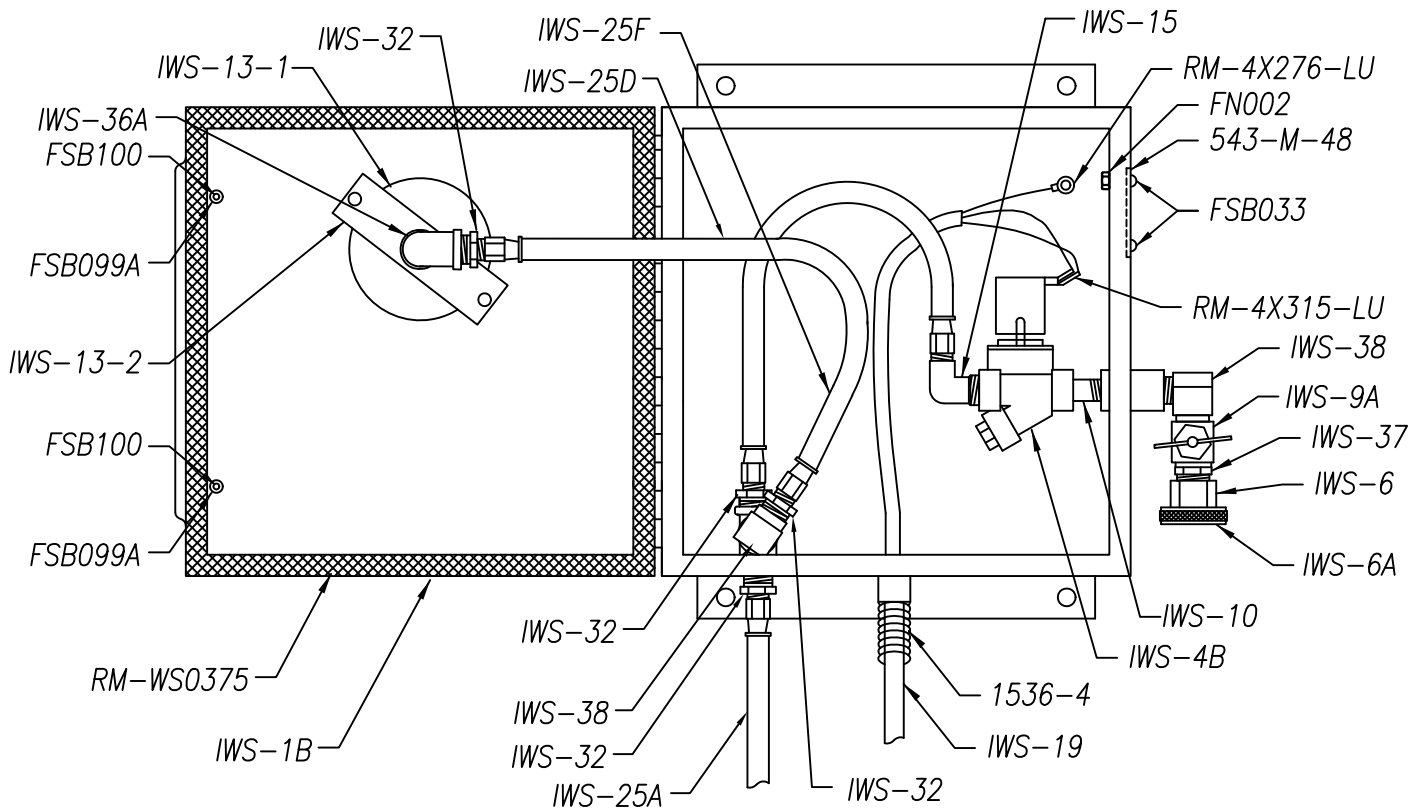

PART #	DESCRIPTION	
IWS-1B	ELECTRICAL BOX, 8" X 8" X 4"	(HOFAB08CH)
IWS-4B	DEMA SOLENOID VALVE 12V. 125 PSI	
IWS-6	ADAPTER, GARDEN HOSE, 3/4"	(71938)
IWS-6A	WASHER, 3/4" GARDEN HOSE ADAPTER	(70332)
IWS-9A	SHUT-OFF NEEDLE VALVE 1/4"	(42836)
IWS-10	NIPPLE, 1/4" x 1 1/2"	(41579)
1536-4	CORD RESTRAINT, 3/8"	(HJ1015B)
IWS-13-1	GAUGE, PRESSURE, PAN MOUNT (ORDER IWS-13-2)	(5HK75)
IWS-13-2	MOUNTING KIT F/GUAGE (IWS-13-1)	(5A046)
IWS-15	ELBOW, 1/4" x 1/4" MALE	
IWS-19	CORD, 18-3(SJ) X 6'	
IWS-25A	WATER LINE, 1/4" x 6' W/SWIVEL	
IWS-25F	WATER LINE, 8 1/2" W/SWIVEL	(801-4-BLU-RL)
IWS-25D	PRESSURE LINE, 9" W/SWIVEL	(K4131-06)
IWS-32	CONNECTOR, MALE {4}	(VS48F-4-4)
IWS-36A	ELBOW, 1/4" 90°, GALVANIZED	(41445)
IWS-37	BUSHING, 1/2"-1/4", BRASS	(41405)
IWS-38	BRASS STREET ELBOW, 1/4" {2}	(46974)
RM-WS0375	WEATHER STRIPPING, 1/8" x 3/8" x 10' LONG	
543-M-48	COVER PLATE F/RECEPTACLE	
FSB033	SB 8-32 x 5/16 {2}	
FSB100	SB 10-32 x 1/2 SH/PAN HD MS {2}	
FSB099-A	.007 BUNO O-RING {2}	
RM-4X276-LU	RING TERMINAL	
RM-4X315-LU	QUICK DISCONNECT {2}	
FN002	N 8-32 NUT	

# 24V INTERNAL WETTING SYSTEM CONTROL MODULE NOVEMBER 2006 WITH HIGH PRESSURE SOLENOID (300 PSI) STYLE B

PART#: 367C-B-CM

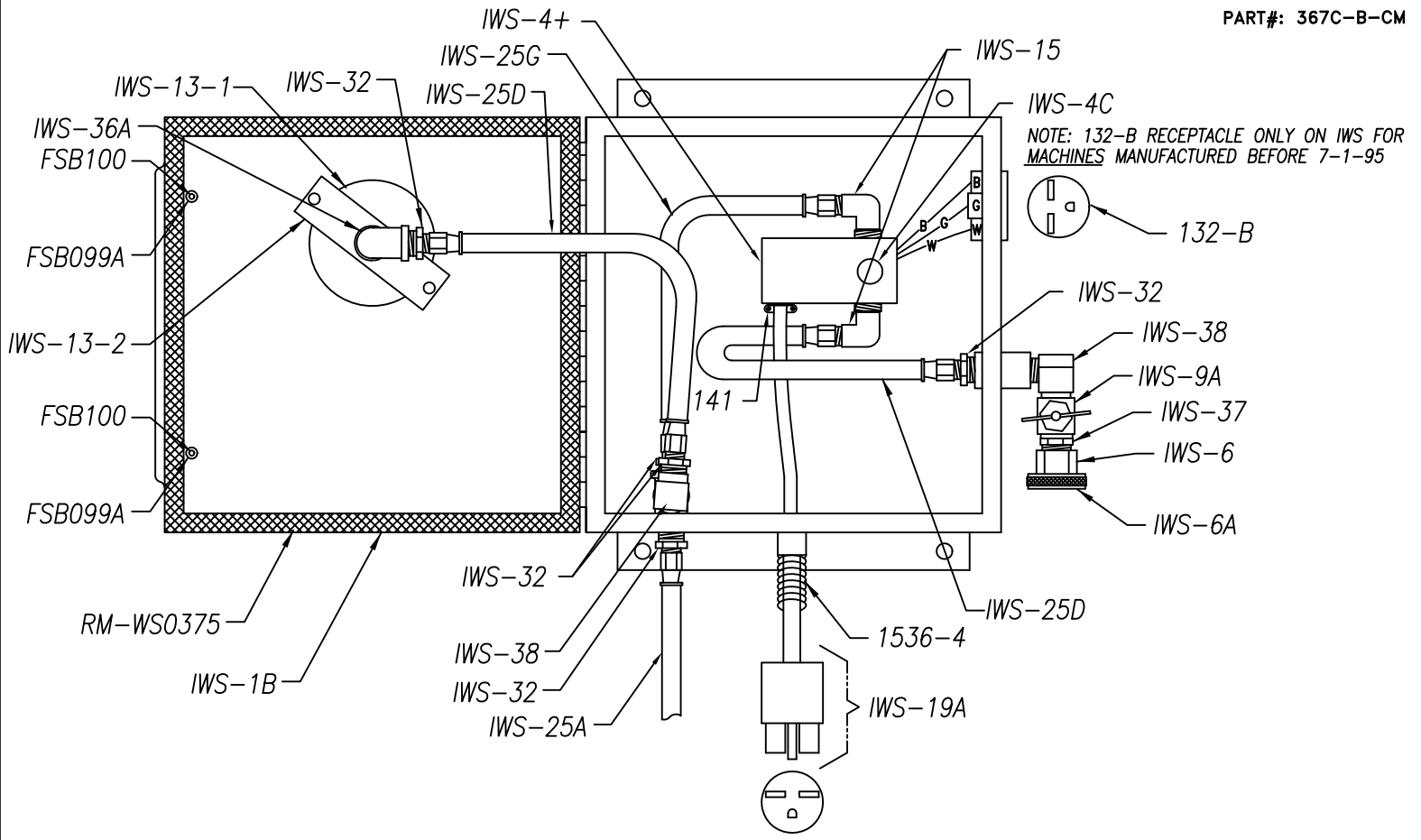

PART #	DESCRIPTION	
IWS-1B	ELECTRICAL BOX, 8" X 8" X 4"	(HOFA808CH)
IWS-4C	SOLENOID VALVE, 300 PSI, 24V	
IWS-4+	SOLENOID COIL, 24V.	
IWS-6	ADAPTER, GARDEN HOSE 3/4"	(71938)
IWS-6A	WASHER, 3/4" GARDEN HOSE ADAPTER	(70332)
IWS-9A	SHUT-OFF NEEDLE VALVE 1/4"	(42836)
132-B	RECEPTACLE, NEMA #6-15R, 24VAC	
1536-4	CORD RESTRAINT, 3/8"	(HJ1015B)
IWS-13-1	GAUGE, PRESSURE, PAN MOUNT (ORDER IWS-13-2)	(5HK75)
IWS-13-2	MOUNTING KIT F/GUAGE (ORDER IWS-13-1)	(5A046)
IWS-15	ELBOW, 1/4" X 1/4" MALE	
IWS-19A	CORD & PLUG, 18-3(SJ) X 6' {IWS-19} w/6-15P {126-B}	
IWS-25A	WATER LINE, 1/4" X 6' w/SWIVEL	
IWS-25G	WATER LINE, 1/4" X 6" w/SAE 37 SWIVEL	(801-4-BLU-RL)
IWS-25D	PRESSURE LINE, 1/4" X 9" w/SAE 37 SWIVEL	(K4131-06)
IWS-32	CONNECTOR, MALE {7}	(VS48F-4-4)
IWS-36A	ELBOW, 1/4" 90°, GALVANIZED	(41445)
IWS-37	BUSHING, 1/2"-1/4", BRASS	(41405)
IWS-38	BRASS STREET ELBOW, 1/4" {4}	(46974)
RM-WS0375	WEATHER STRIPPING, 1/8" X 3/8" X 10' LONG	
141	3/8" CORD CLAMP	
FSB100	SB 10-32 X 1/2 SH/PAN HD MS {2}	
FSB099-A	.007 BUNO O-RING {2}	
RM-CON10001-GY	WIRE CONNECTOR, GREY	
RM-CON10003-OR	WIRE CONNECTOR, ORANGE (2)	
FW017	W 8-32 INTERNAL TOOTH LOCK WASHER {2 NOT SHOWN}	
FSB033	SB 8-32 X 5/16 {2 NOT SHOWN}	
	WIRE, 14ga, 8" BLACK	
	WIRE, 14ga, 8" WHITE	
	WIRE, 14ga, 8" GREEN	

# 24V INTERNAL WETTING SYSTEM CONTROL MODULE WITH HIGH PRESSURE SOLENOID (300 PSI)

NOVEMBER 2006

PART#: ELU95-367C-B-CM  
(U.S.A.)

PART#: ELU95-367C-C-CM  
(OVERSEAS)

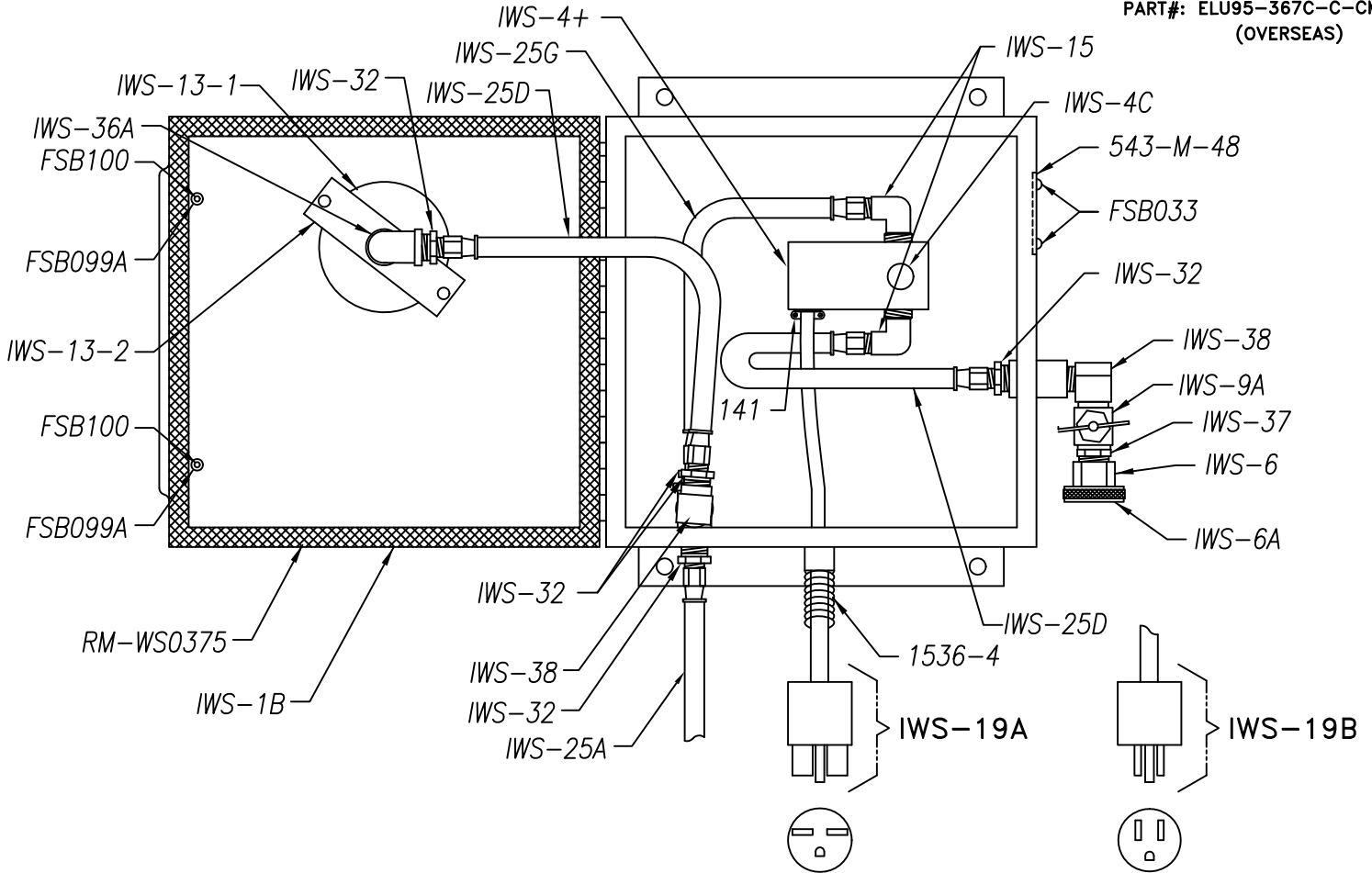

PART #	DESCRIPTION
IWS-1B	ELECTRICAL BOX, 8" X 8" X 4" (H0FA808CH)
IWS-4C	SOLENOID VALVE, 300 PSI
IWS-4+	SOLENOID COIL, 24 V.
IWS-6	ADAPTER, GARDEN HOSE, 3/4" (71938)
IWS-6A	WASHER, 3/4" GARDEN HOSE ADAPTER (70332)
IWS-9A	SHUT-OFF NEEDLE VALVE 1/4" (42836)
1536-4	CORD RESTRAINT, 3/8" (HJ1015B)
IWS-13-1	GAUGE, PRESSURE, PAN MOUNT (5HK75)
IWS-13-2	MOUNTING KIT F/GUAGE (5A046)
IWS-15	ELBOW, 1/4" X 1/4" MALE {2}
IWS-19A	CORD & PLUG, 18-3(SJ) X 6' {IWS-19} w/6-15P {126-B} {U.S.}
IWS-19B	CORD & PLUG, 18-3(SJ) X 6' {IWS-19} w/5-15P {127} {OVERSEAS}
IWS-25A	WATER LINE, 1/4" X 6' w/SWIVEL
IWS-25G	WATER LINE, 1/4" X 6" w/SAE 37 SWIVEL (801-4-BLU-RL)
IWS-25D	PRESSURE LINE, 1/4" X 9" w/SAE 37 SWIVEL (K4131-06)
IWS-32	CONNECTOR, MALE {5} (VS48F-4-4)
IWS-36A	ELBOW, 1/4" 90° (41445)
IWS-37	BUSHING, 1/2"-1/4", BRASS (41405)
IWS-38	BRASS STREET ELBOW, 1/4" {4} (46974)
RM-WS0375	WEATHER STRIPPING 3/8"
141	3/8" CORD CLAMP
543-M-48	COVER PLATE F/RECEPTACLE
FSB033	SB 8-32 X 5/16 {4} {2 NOT SHOWN}
FSB100	SB 10-32 X 1/2 SH/PAN HD MS {2}
FSB099-A	.007 BUNO O-RING {2}
RM-CON10001-GY	WIRE CONNECTORS, GREY {2}
FW017	W 8-32 INT. TOOTH LOCK WASHER {2 NOT SHOWN}

KRENDL MACHINE COMPANY  
 MODEL #367C  
 INTERNAL WETTING SYSTEM  
 (1-JET CONNECTOR TUBE)

APRIL 2009  
 PART#: 367C-3A (3")  
 367C-4A (4")  
 367C-5A (5")

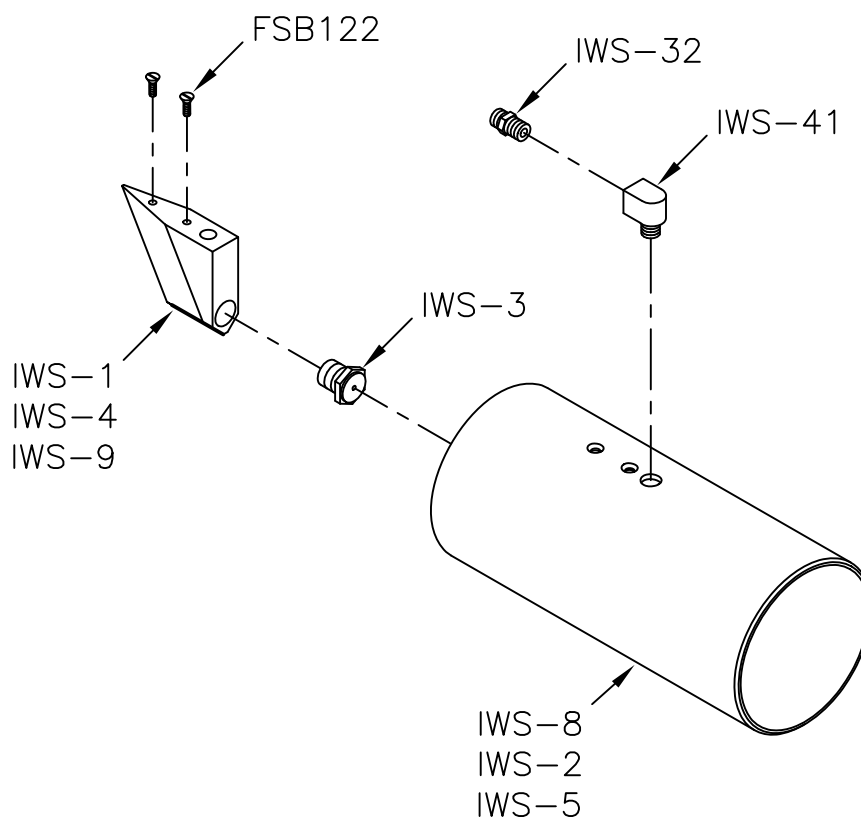

PART NO	-----	DESCRIPTION
IWS-8	-----	3" CONNECTOR TUBE
IWS-2	-----	4" CONNECTOR TUBE
IWS-5	-----	5" CONNECTOR TUBE
IWS-1	-----	NOZZLE MOUNT, 3"
IWS-4	-----	NOZZLE MOUNT, 4"
IWS-9	-----	NOZZLE MOUNT, 5"
IWS-32	-----	CONNECTOR, MALE
IWS-41	-----	ELBOW, REDUCING 1/4" TO 1/8"
FSB122	-----	SB 10-32 x 3/8 FHS (2)
IWS-3	-----	SPRAY TIP, AQUA, 3/8BD-3-.50

# KRENDL MACHINE COMPANY

MARCH 2009  
PART#: 367-3C-CONE

## MODEL #425/450/500

### 3" IWS HOSE ASSY W/CONE TIP, REDUCER, & HOSE

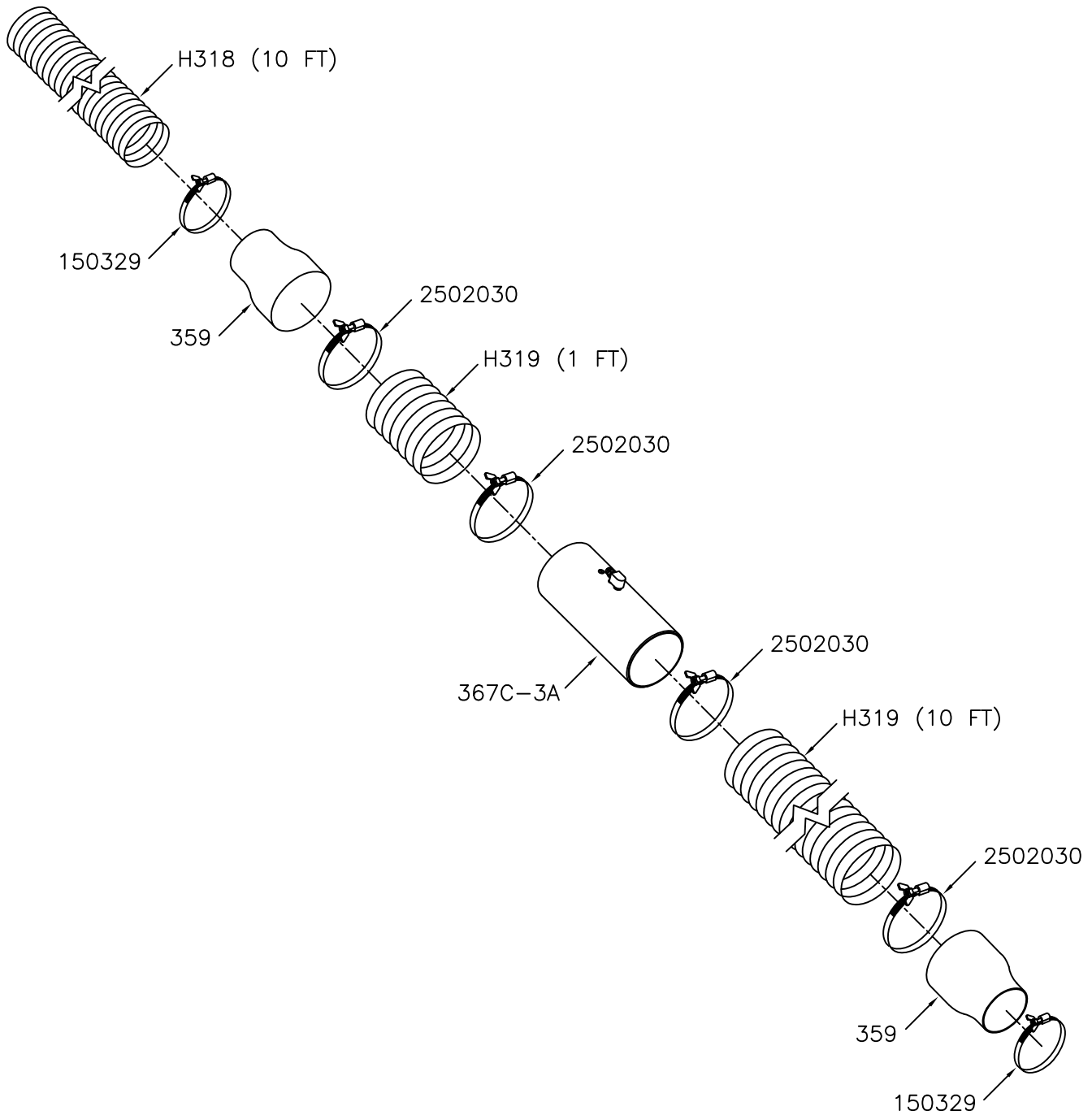

PART NO	-----	DESCRIPTION
359	-----	3" TO 2 1/2" REDUCER (2)
150329	-----	2 1/2" HOSE CLAMP W/WINGNUT (2)
2502030	-----	3" HOSE CLAMP (4)
H318	-----	2 1/2" FLEXHAUST (10 FT)
H319	-----	3" FLEXHAUST (10 FT + 1 FT)
367C-3A	-----	3" CONNECTOR TUBE ASSY

MODEL #1300/2300

4" IWS HOSE ASSY W/CONE TIP, REDUCER, & HOSE

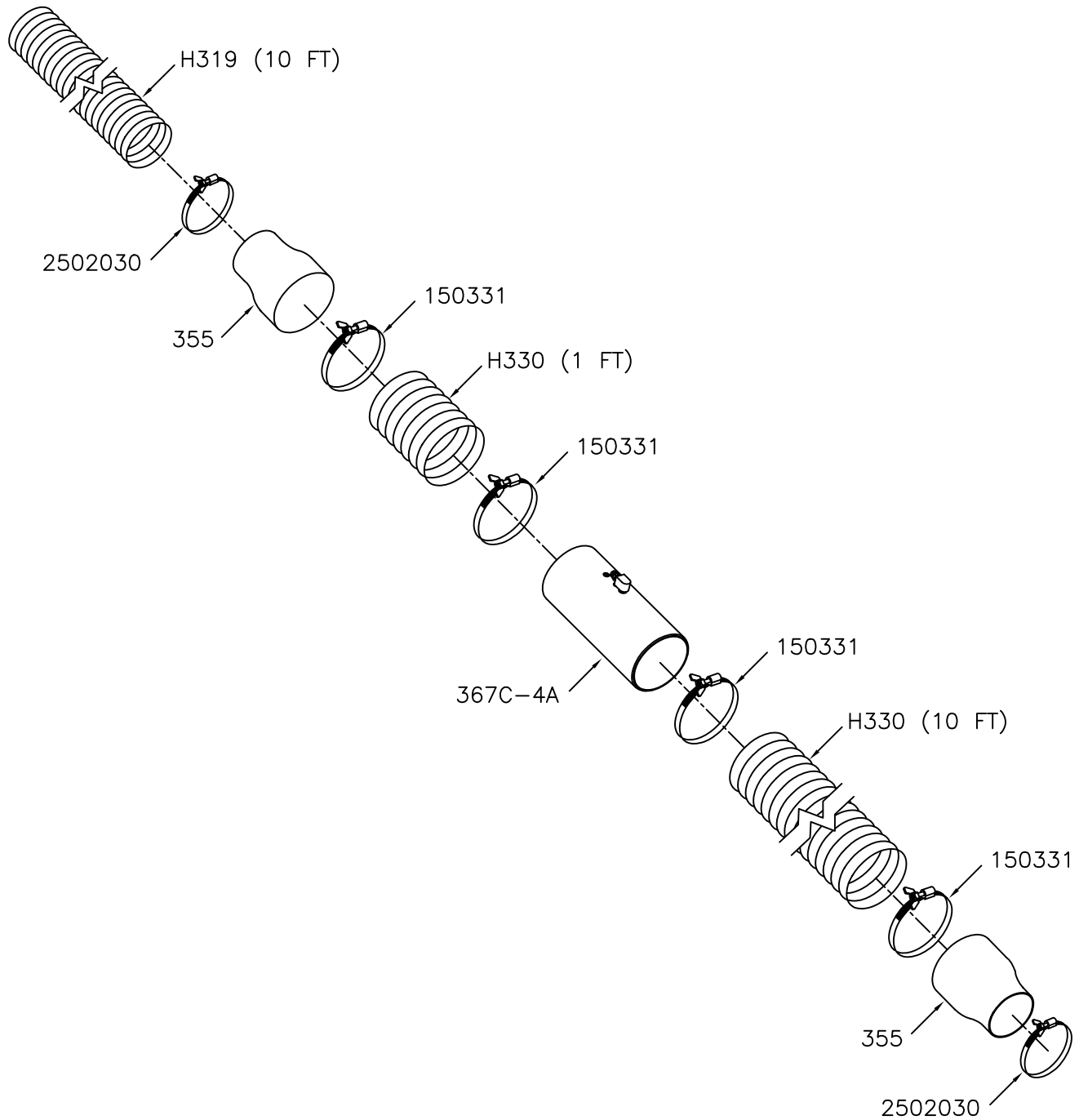

PART NO	-----	DESCRIPTION
355	-----	4" TO 3" REDUCER (2)
2502030	-----	3" HOSE CLAMP W/WINGNUT (2)
150331	-----	4" HOSE CLAMP W/WINGNUT (4)
H319	-----	3" FLEXHAUST (10 FT)
H330	-----	4" FLEXHAUST (10 FT + 1 FT)
367C-4A	-----	4" CONNECTOR TUBE ASSY

# KRENDL MACHINE COMPANY

MARCH 2009  
PART#: 367C-5C-CONE

## MODEL #4000/4200/5200

### 5" IWS HOSE ASSY W/CONE TIP, REDUCER, & HOSE

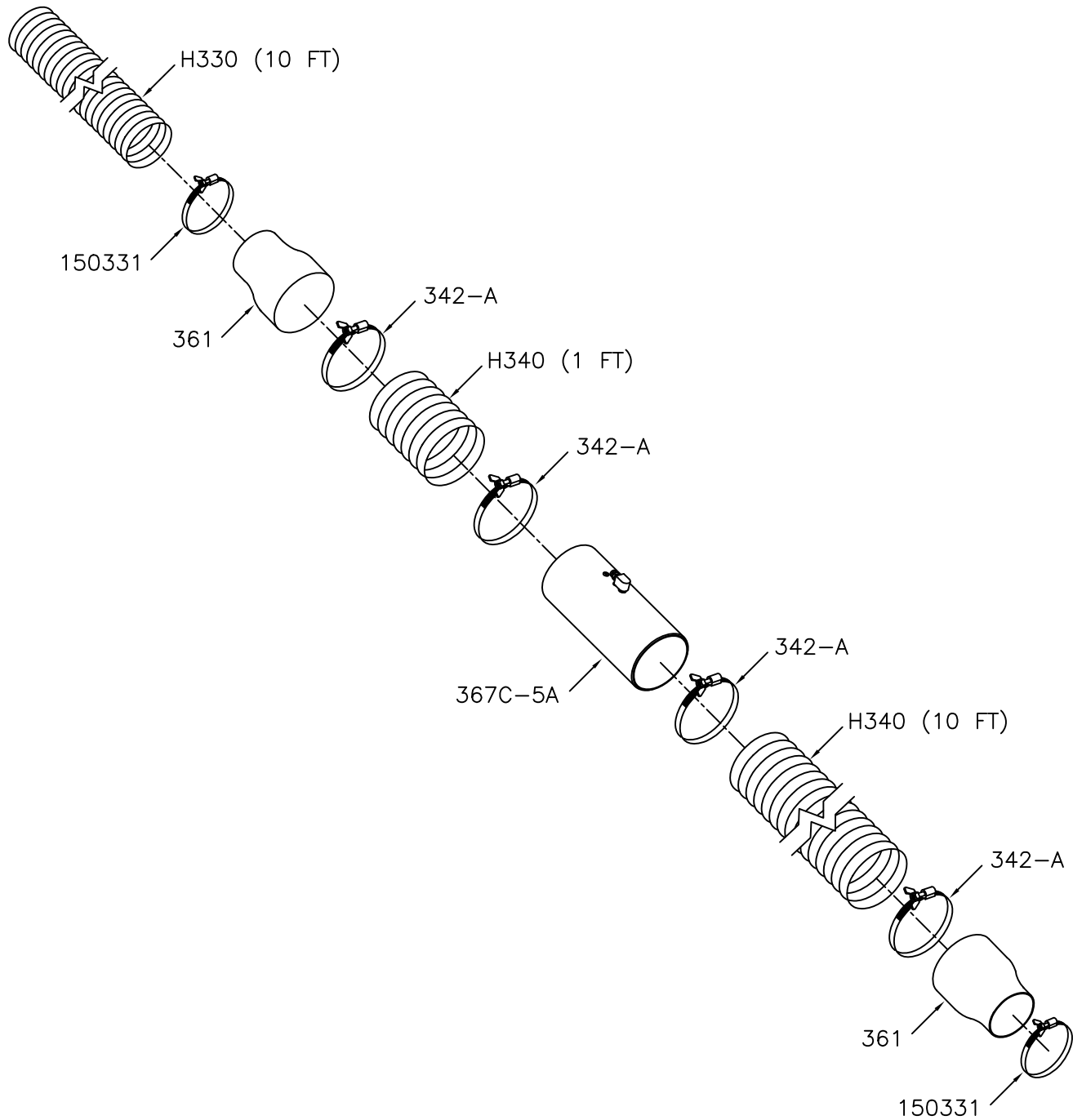

PART NO	-----	DESCRIPTION
361	-----	5" TO 4" REDUCER (2)
150331	-----	4" HOSE CLAMP W/WINGNUT (2)
342-A	-----	5" HOSE CLAMP W/WINGNUT (4)
H330	-----	4" FLEXHAUST (10 FT)
H340	-----	5" FLEXHAUST (10 FT + 1 FT)
367C-5A	-----	5" CONNECTOR TUBE ASSY

KRENDL MACHINE CO. INC.  
 MODEL #367C  
 CONNECTOR TUBE ASSY.  
 (2-JET CONNECTOR TUBE)

MARCH 2009

PART#: 367C-7 (2")  
 367C-3 (2 1/2")  
 367C-5 (3")

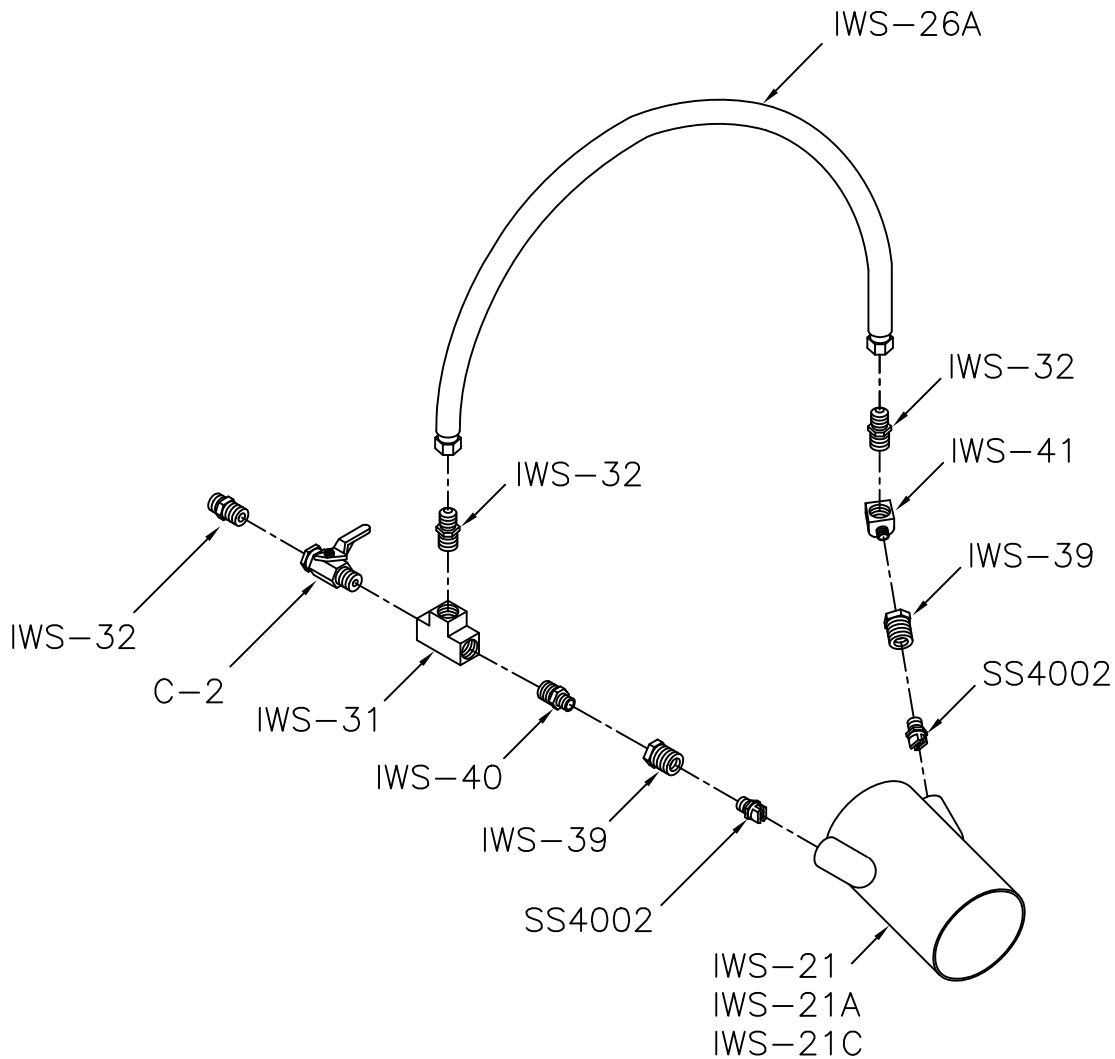

PART NO	-----	DESCRIPTION
IWS-21	-----	3" CONNECTOR TUBE
IWS-21A	-----	2 1/2" CONNECTOR TUBE
IWS-21C	-----	2" CONNECTOR TUBE
IWS-26A	-----	CROSS-OVER LINE, 1/4" x 10" W/SWIVEL
IWS-31	-----	TEE, BRASS (1203P-4)
IWS-32	-----	CONNECTOR, MALE
IWS-39	-----	BUSHING, 3/8" TO 1/8" (TAPPED)
IWS-40	-----	NIPPLE, REDUCING 1/4" TO 1/8"
IWS-41	-----	ELBOW, REDUCING 1/4" TO 1/8"
C-2	-----	BALL VALVE, 1/4" COMM,WC,IWS
SS4002	-----	SPRAY JET 4002

# KRENDL MACHINE COMPANY

MARCH 2009  
PART#: 367C-3C

## MODEL #425/450/500

### 3" CONNECTOR ASSY W/TIPS, REDUCER, & HOSE

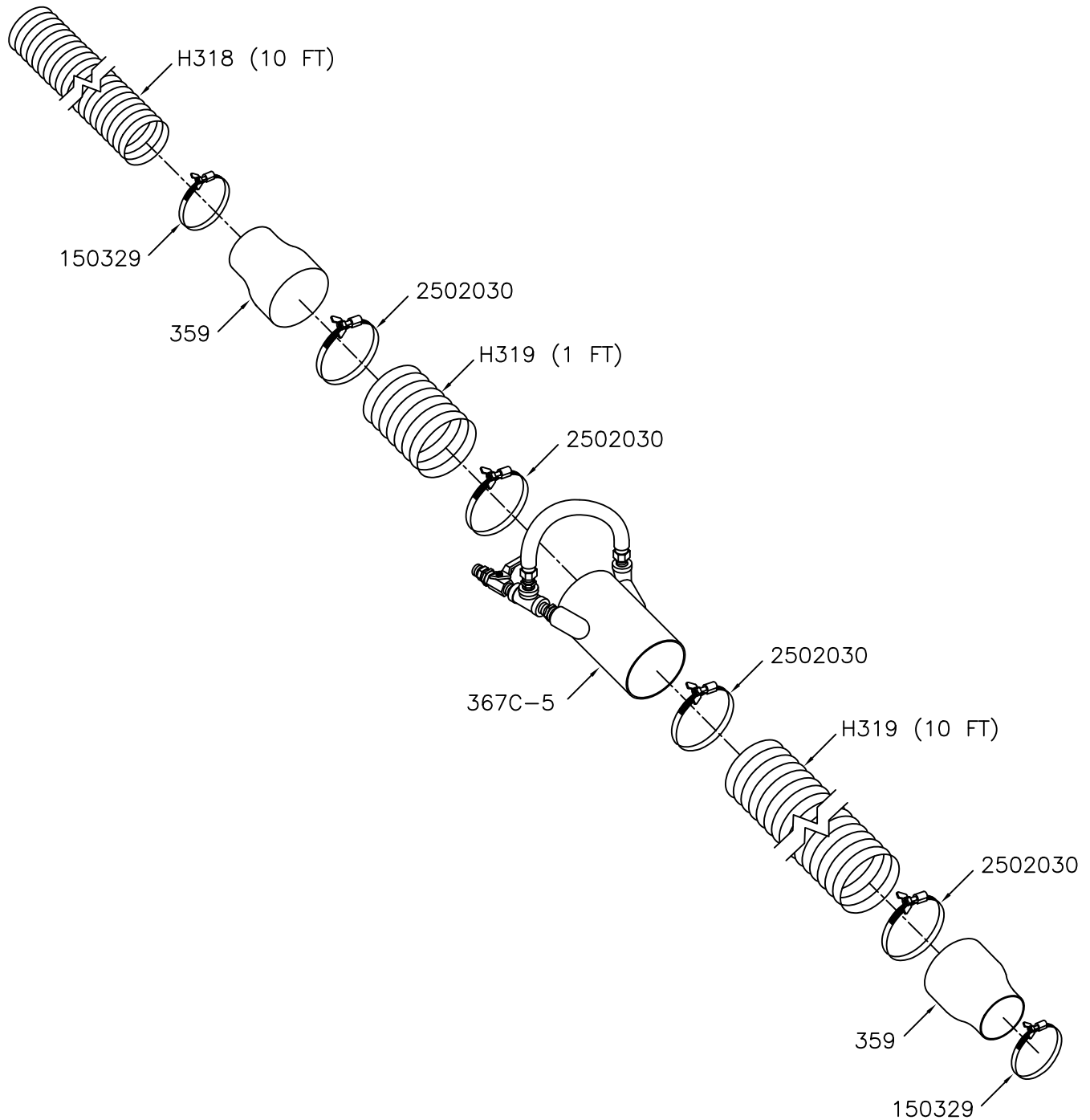

PART NO	-----	DESCRIPTION
359	-----	3" TO 2 1/2" REDUCER (2)
150329	-----	2 1/2" HOSE CLAMP W/WINGNUT (2)
2502030	-----	3" HOSE CLAMP (4)
H318	-----	2 1/2" FLEXHAUST (10 FT)
H319	-----	3" FLEXHAUST (10 FT + 1 FT)
367C-5	-----	3" CONNECTOR TUBE ASSY

# KRENDL MACHINE COMPANY

MARCH 2009  
PART#: 367C-4C

## MODEL #1300/2300

### 4" CONNECTOR ASSY W/TIPS, REDUCER, & HOSE

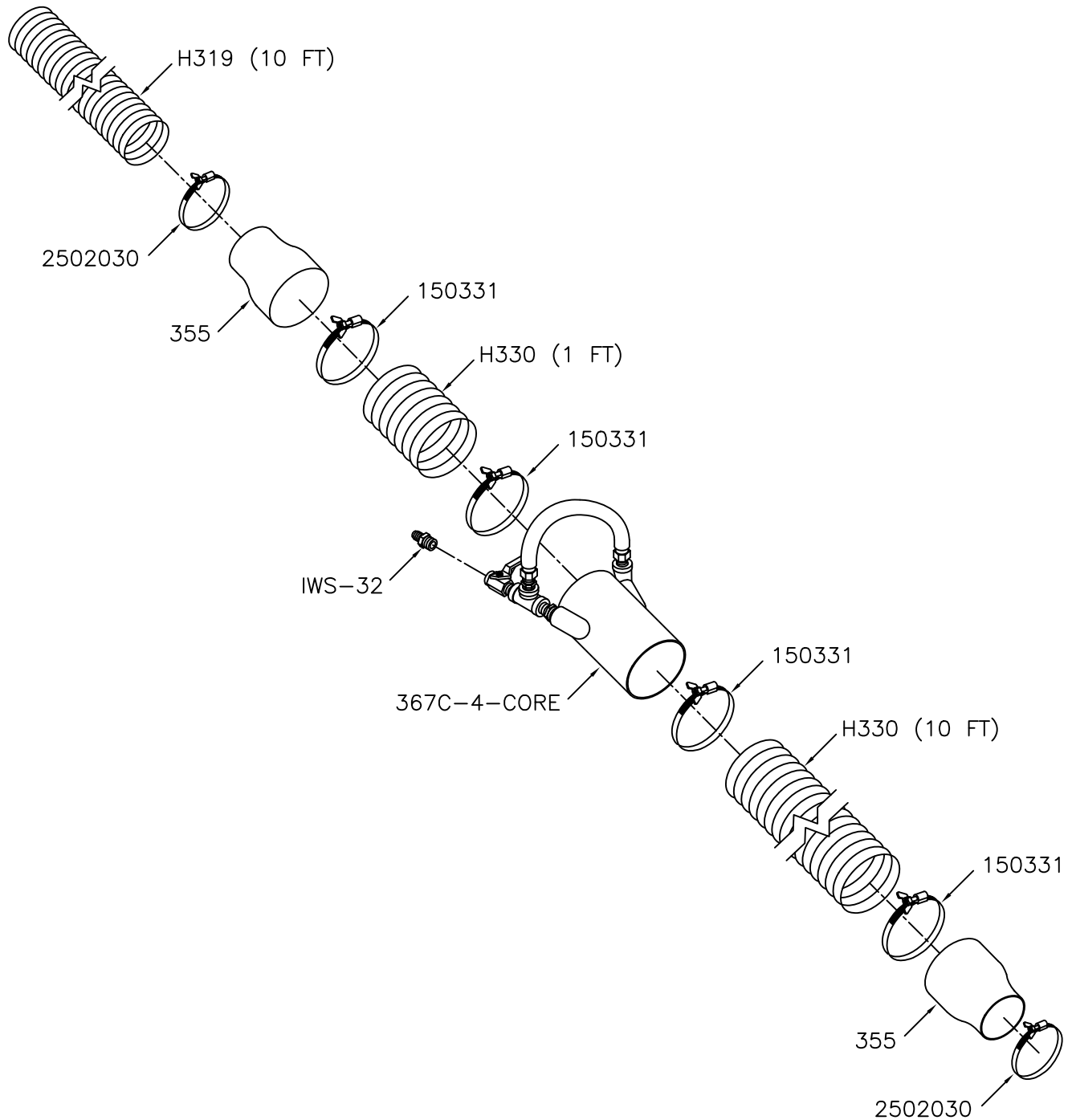

PART NO	-----	DESCRIPTION
355	-----	4" TO 3" REDUCER (2)
2502030	-----	3" HOSE CLAMP W/WINGNUT (2)
150331	-----	4" HOSE CLAMP W/WINGNUT (4)
H319	-----	3" FLEXHAUST (10 FT)
H330	-----	4" FLEXHAUST (10 FT + 1 FT)
367C-4-CORE	-----	4" CONNECTOR TUBE ASSY
IWS-32	-----	CONNECTOR, MALE, WITH VS

MODEL #4000/4200/5200

5" CONNECTOR ASSY W/TIPS, REDUCER, & HOSE

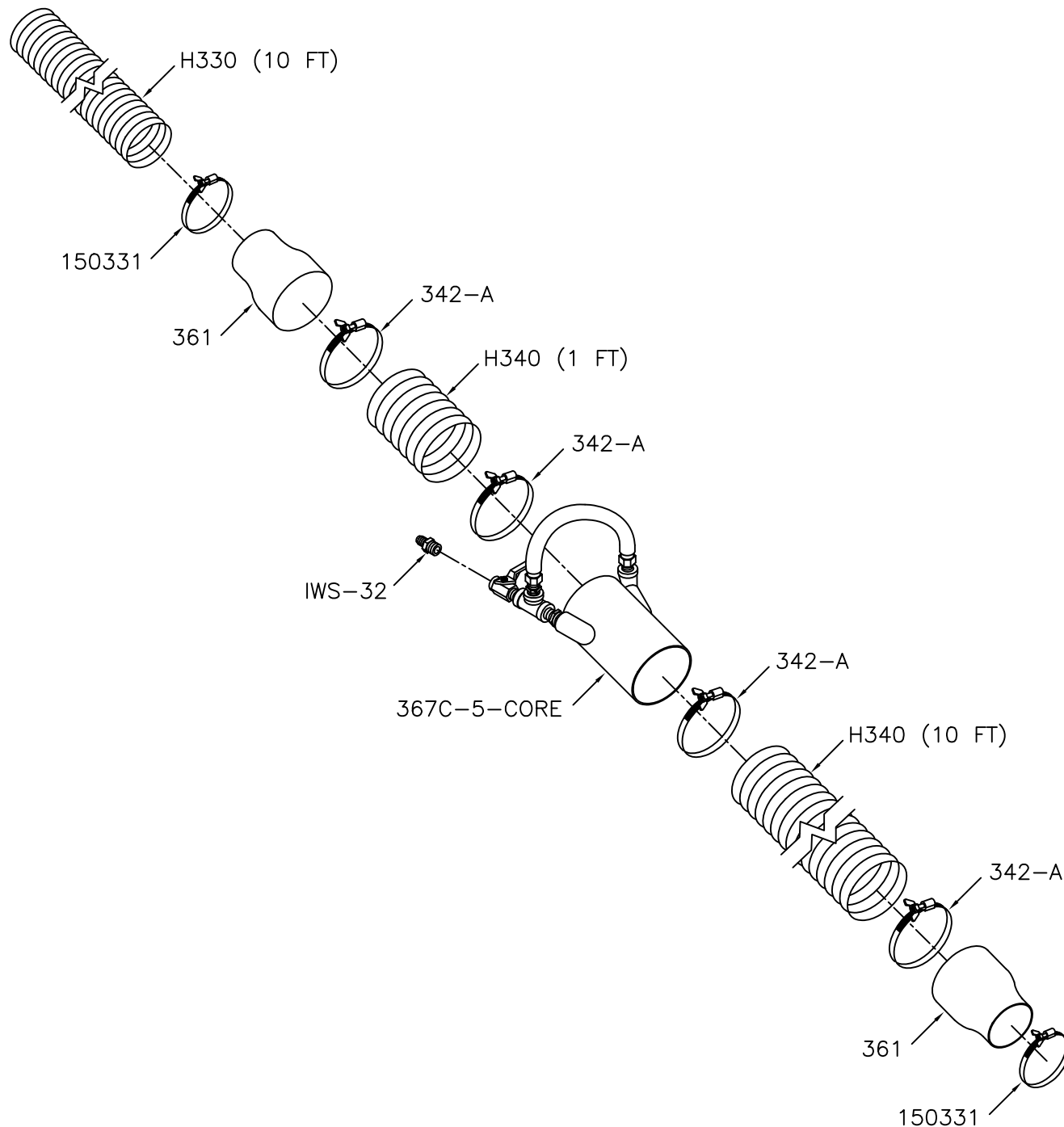

PART NO	-----	DESCRIPTION
361	-----	5" TO 4" REDUCER (2)
150331	-----	4" HOSE CLAMP W/WINGNUT (2)
342-A	-----	5" HOSE CLAMP W/WINGNUT (4)
H330	-----	4" FLEXHAUST (10 FT)
H340	-----	5" FLEXHAUST (10 FT + 1 FT)
367C-5-CORE	-----	5" CONNECTOR TUBE ASSY
IWS-32	-----	CONNECTOR, MALE, WITH VS

MODEL #1300/2300/KS260

4" CONNECTOR ASSY W/TIPS, REDUCER, & HOSE  
QUICK DISCONNECT

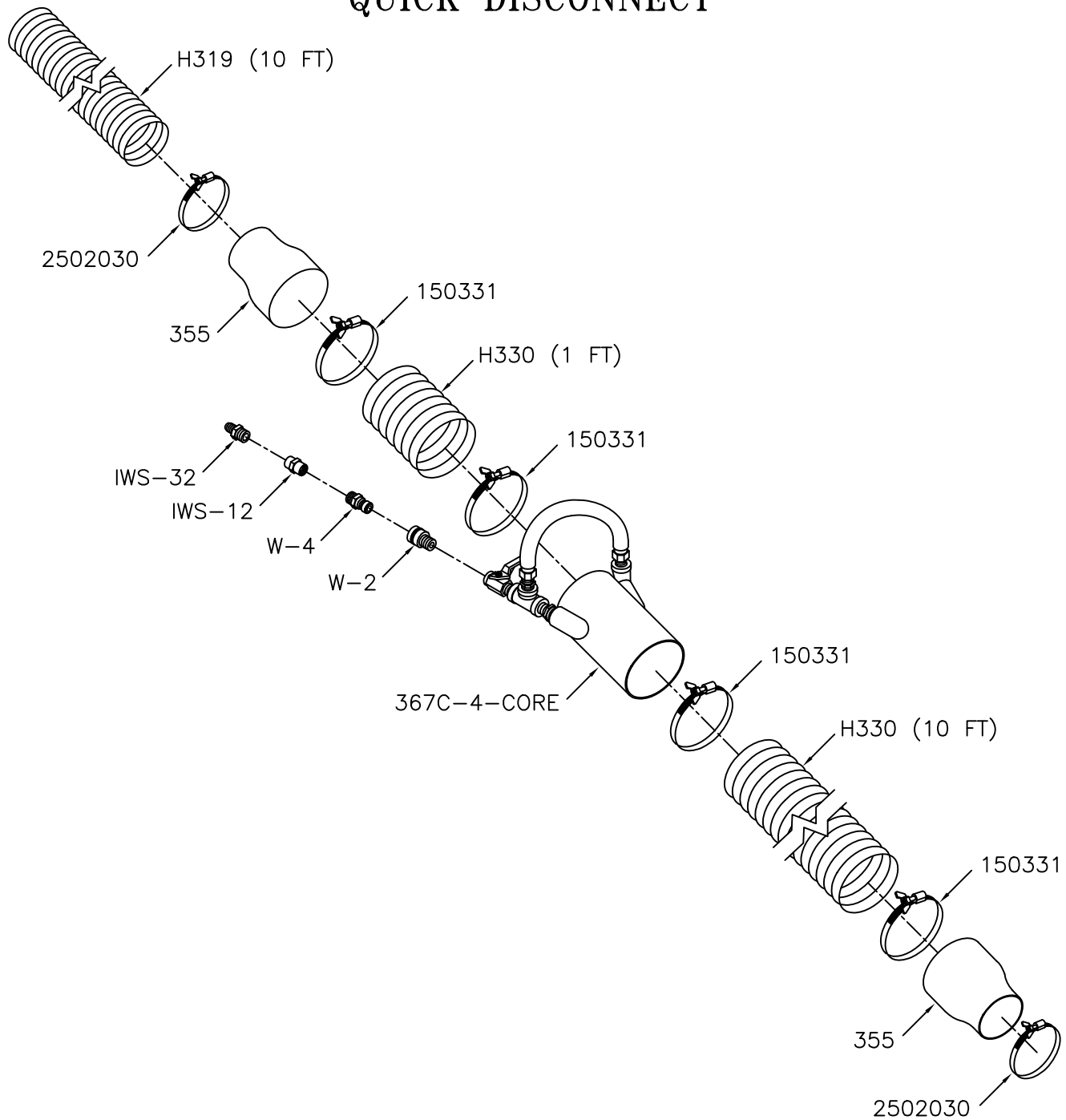

PART NO	-----	DESCRIPTION
355	-----	4" TO 3" REDUCER (2)
2502030	-----	3" HOSE CLAMP W/WINGNUT (2)
150331	-----	4" HOSE CLAMP W/WINGNUT (4)
H319	-----	3" FLEXHAUST (10 FT)
H330	-----	4" FLEXHAUST (10 FT + 1 FT)
367C-4-CORE	-----	4" CONNECTOR TUBE ASSY
IWS-32	-----	CONNECTOR, MALE, WITH VS
IWS-12	-----	COUPLER, 1/4", BRASS
W-4	-----	NIPPLE, QUICK DISCONNECT, 1/4"
W-2	-----	COUPLER, QUICK DISCONNECT, 1/4"

# KRENDL MACHINE COMPANY

MARCH 2009  
PART#: 367C-5-KS250

## MODEL #4000/4200/5200/KS260

### 5" CONNECTOR ASSY W/TIPS, REDUCER, & HOSE QUICK DISCONNECT

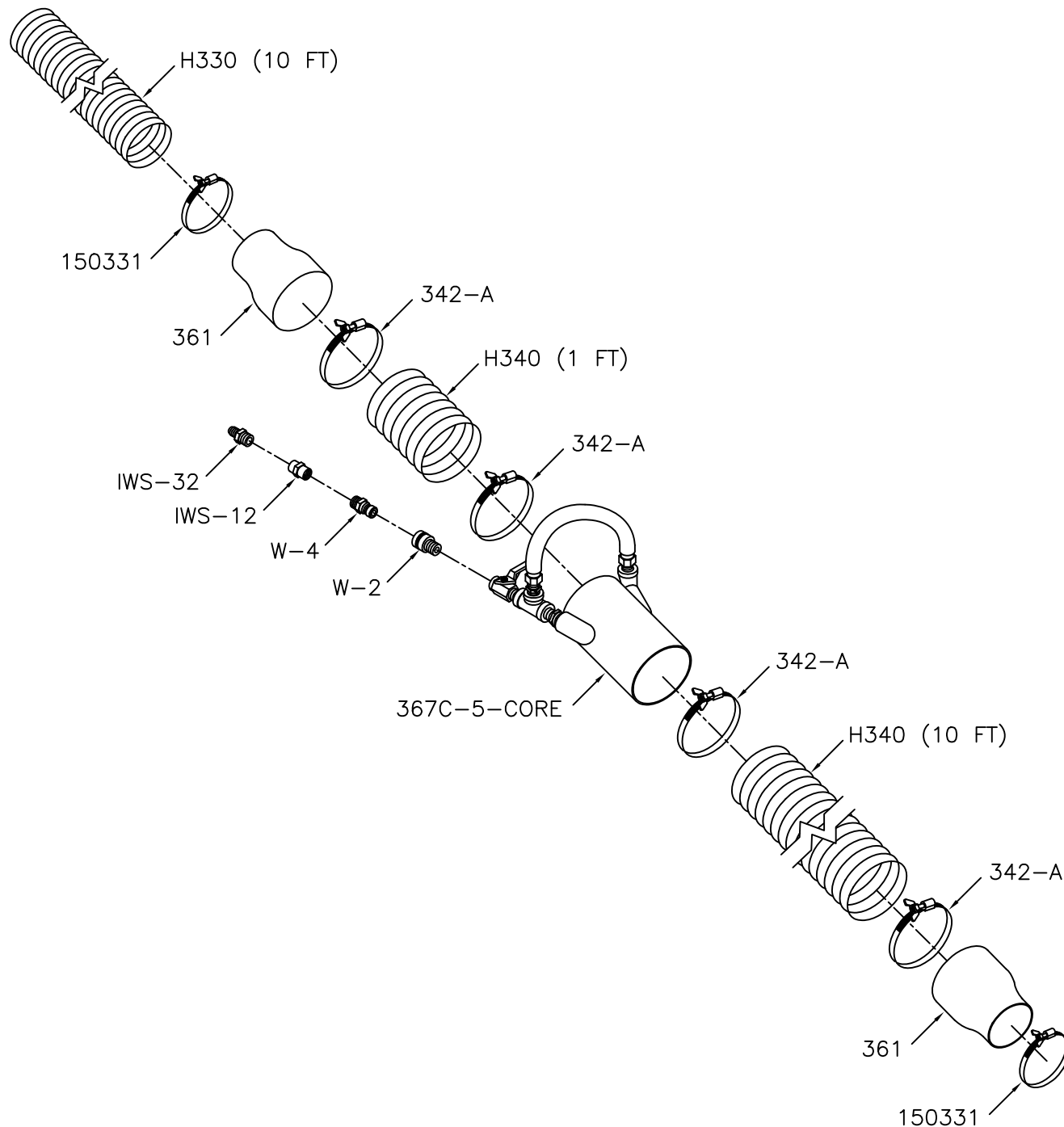

PART NO	-----	DESCRIPTION
361	-----	5" TO 4" REDUCER (2)
150331	-----	4" HOSE CLAMP W/WINGNUT (2)
342-A	-----	5" HOSE CLAMP W/WINGNUT (4)
H330	-----	4" FLEXHAUST (10 FT)
H340	-----	5" FLEXHAUST (10 FT + 1 FT)
367C-5-CORE	-----	5" CONNECTOR TUBE ASSY
IWS-25E	-----	WATER LINE W/SWIVEL (1/4" x 30')
IWS-32	-----	CONNECTOR, MALE, WITH VS
IWS-12	-----	COUPLER, 1/4", BRASS
W-4	-----	NIPPLE, QUICK DISCONNECT, 1/4"
W-2	-----	COUPLER, QUICK DISCONNECT, 1/4"